

Conventional Farm Fencing

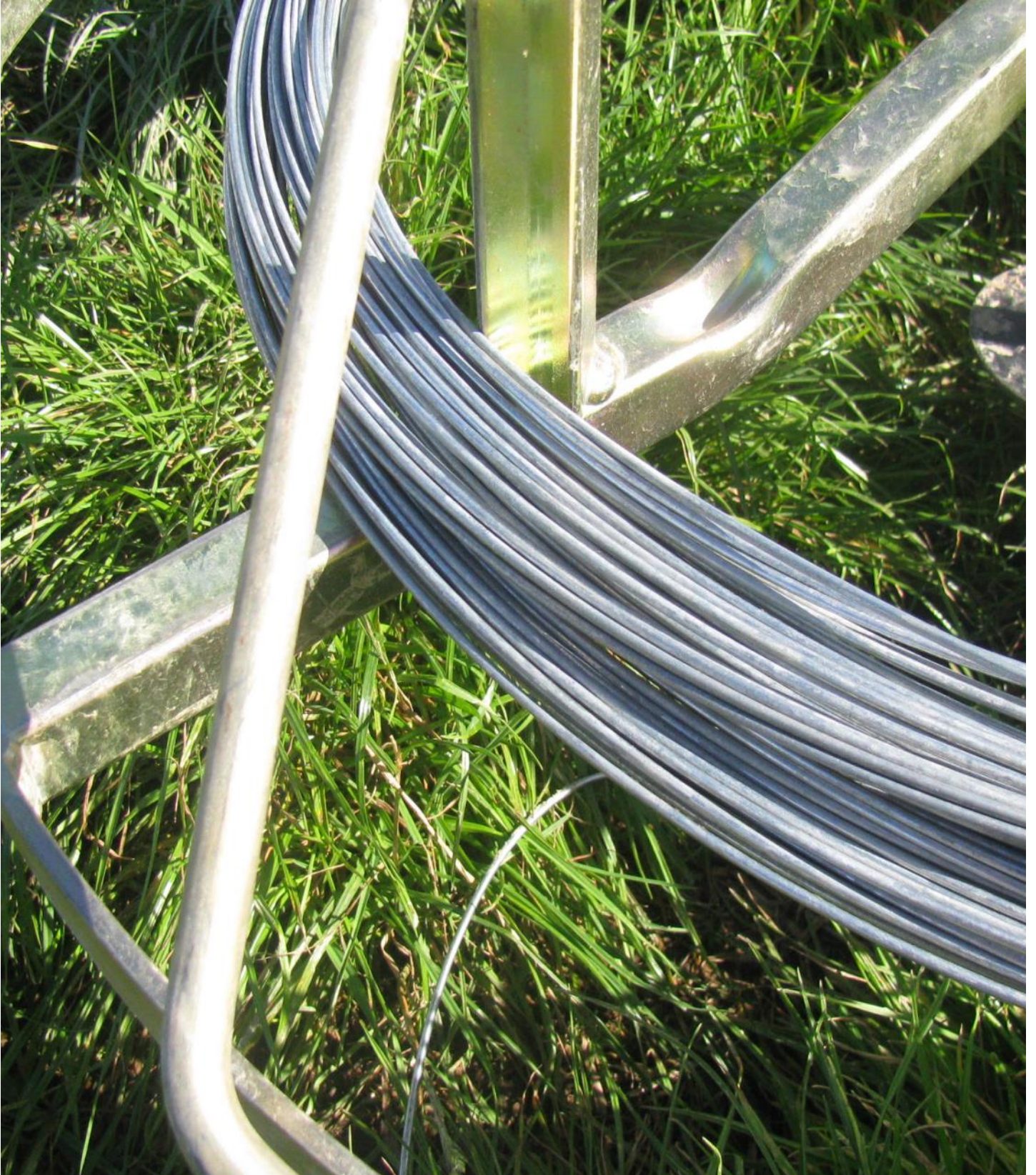

Contents

Introduction	5
Section 1	6
Fence Design	6
Designing a fence	11
Section 2	18
Fencing Material	18
Post materials	19
Types of post.....	23
Battens (or droppers).....	24
Timber railings	25
Wire	26
Fabricated netting.....	32
Staples	36
Nails	38
Permanent strainers	39
Crimps/joiners	39
Rust protection	40
Anchoring Material	40
Flood gates.....	41
Gates.....	42
Section 3	43
Fencing tools – non mechanical.....	43
Mechanical Tools	47
Maintaining Tools	48
Safety Equipment.....	49
Section 4	51
Fence Components	51
Horizontal Stay Assembly.....	59
Diagonal Stay assembly.....	63
Ramming in the soil	65
Angle posts	66
Line posts or intermediate posts	67
Wire tying	67
Joining.....	67
Breaking off the wire	74
Attaching battens & droppers.....	75
Wire droppers.....	76
Gates.....	77
Latches.....	83
Rails.....	84
Flood Gates.....	84
Section 5	87
Building the fence	87

Replacing a post	103
Dismantling the fence	104
Adding Electricity.....	105
Netting	107
Section 6.....	113
Health & Safety	113

Introduction

The purpose of a farm fence is to restrict movement of stock. A barrier either **prevents** or **deters** stock from crossing.

Prevention: Non electric fences must physically stop animals by ensuring there are no spaces or weak areas through which an animal can squeeze, push, or create a gap.

Non electric fences must be able to withstand the maximum force that can be placed upon them.

Deterrence: These are largely electric fences. The electric current acts as a very persuasive deterrent for most animals. To a lesser extent one or two barbed wires strategically placed on a conventional fence may do the same thing. Today farmers have largely replaced the one or two strands of barbed wire with one or two electric wires.

Keep in mind that the demands on a fence are different depending on what is behind it:

- Lambs – can get through small gaps and have little respect for fences.
- Goats –are very smart and find holes along the fence line, or they push through a weak area.
- Bulls – are large and have a great deal of weight to throw around.



Stock will go to great lengths to get a decent feed



-
-
-
-
-
-
-
-
-
-

Constant pushing like this increases the wear and tear on the fence and shortens its lifespan



Fence design features have to match the animal that you are trying to contain.



Section 1

Fence Design

Common fence types

The type of animal is not the only deciding factors when it comes to fence design. Topography, availability of material, laws, soil types and budget also dictate the design of a fence.

It is because of these design factors a number of fence designs have developed.

An effective fence design will balance **effectiveness, economics** and **tradition**

The most common types of non-electric fences fall into three categories.

1 Multi wire, post and batten

Often referred to as 'conventional' fences and sometimes 'post and wire' fences. Often these fences also incorporate electrified wires.



This is a typical post and batten fence. There are round posts spaced at 4 metres, 5 battens between each post and 7 wires of 2.5 high tensile wire.

Variations on this design allow for:

- 7 – 10 or more wires
- Round, ½ round or ¼ posts
- Different sized posts at different lengths
- Post spacing – 4-5 metres apart
- Battens – 3-5 between posts
- Wire – mild, high tensile, barbed, No.8(5mm), 3.15mm or 2.5mm
- Different wire spacing
- Different strainer assemblies
- Different anchoring /stabilizing systems

2 Post and Wire



Post and wire fence with round posts spaced at 3 - 5 metres and 8-9 wires of 2.5mm high tensile wire.

Variations may occur with:

- Number of wires
- Wire – mild, high tensile, barbed, No.8 (4mm), 3.15mm, or 2.5mm
- Post spacing – 3 – 5 metres apart
- Post sizes and lengths
- Different wire spacing
- Different strainer assemblies
- Different anchoring / stabilizing systems

3 Fabricated Netting

Description

These types of fences are constructed with pre-fabricated netting with one or two strands of wire to support the netting. Sometimes they also use battens to support the wire although the netting has its own 'built in' stay wires.

Traditionally netting was used for deer fencing and in holding paddocks, laneways or other high-pressure areas. Today it is also used instead of conventional post and wire fences, especially in the South Island. The netting fence however remains the best way of containing young stock especially fawns.

Fencing with netting on hill country is challenging as it can be cumbersome to handle and it is hard to tension over rises and dips.

Variations may occur with:

- Number of wires/height of netting
- Post spacing – 3 – 5 metres apart
- Post sizes and lengths
- Different wire spacing
- Different strainer assemblies
- Different anchoring / stabilizing systems



Netting fences use posts with the vertical and horizontal wires designed to withstand sustained stock pressure in holding areas

4 Post and rail



A typical post and rail fence. This type of fencing is ideal for horse fencing on in areas around gates.

Variations may occur with:

- Number of rails
- Size and thickness of wooden rails
- Different spacing between rails
- Post spacing
- Post sizes and lengths

Designing a fence

Stock type is not the only deciding factor when it comes to fence design. Design is also influenced by:

- Purpose – what stock are you trying to contain (or keep out)
- Topography – steep, flat, undulating
- Soil type – rocky, sandy, swampy
- Law – relating to boundary and roadside fencing
- Tradition – many farmers continue to do things because they have always done it that way.
- Location – coastal areas, flood prone areas, snowy areas. All provide different problems
- Budget
- Fashion and Taste.

Stock Type and classes

Sheep, cows, bulls, deer, horses, young stock (Lambs and calves) All suit some designs better than others.

	Type	Fence Height	Wire Spacing	Wire size & type	Post Spacings No. of battens	Other
Sheep & Beef	Wire & Batten	1150 - 1200	7 – 8 wire	2.5HT or 4mm Mild	4m – 5m 5 battens	
	Post & Wire	1150 1200	9-10 wire	2.5HT or 4mm Mild	2.5m – 5m	
Lambs	Wire & Batten	1150 1100	8 wire	2.5HT or 4mm Mild	4m 5-7 battens	Electrify lower wire
Cows (Dairy)	Wire & Batten	1150 1200	8 wire	2.5HT or 4mm Mild	4m – 5m 5 battens	Electrify top wire
	Post & Wire	1000 - 1100	3 – 4 wire	2.5HT	5m – 12m	Electrify all wires
	Post & Wire	1.9m – 2m		Deer netting	5.5m – 6m	

Topography

Topography dictates

- The tools you use- spade, post-hole borer or post thumper
- Where the fence goes. – e.g., down, or over the ridge
- Stay/end assembly design
- The number of rise and dip posts
- The number and distance between angles.
- The preparation – bulldozing fence lines on steeper rough country

Land	Fence type	Preparation	Strainer Assemblies	Posts/ distance	Tools
Very Steep	Electric Wire & Batten Post & Wire	Bulldoze fence line if possible.	Box Assemblies	Many intermediate posts may be required on uneven country to keep wire close to the ground.	Spade Rammer
Steep	Electric Wire & Batten Post & Wire	Bulldoze fence line.	Box Assemblies	Many intermediate posts may be required on uneven country to keep wire close to the ground	Spade Rammer
Rolling	Electric Wire & Batten Post & Wire Netting	Flatten places for gates.	Diagonal Stay Assemblies Box Assemblies	Rise and dip posts required.	Tractor Borer Spade etc.
Flat	Electric Wire & Batten Post & Wire Netting		Diagonal Stay Assemblies Box Assemblies	Minimum for intended use.	Tractor Borer Spade etc.

Class of land

Where possible, fences can be used to separate one class of land from another whether it is due to different soil types or aspect (sunny, shady, steep undulating, prone to slipping).

Problem areas

- Rocky outcrops
- Unstable streams, slopes – fencing straight up and down slopes means that the fence will suffer less from snow damage, boulder damage, slipping.
- Gullies or areas susceptible to floods
- Trees and roots

Dips & Bends

Avoid these if possible – every dip will require a tie-down or foot. Likewise, a bend will require bigger posts, angles or strainer assemblies.

Laws

The Law comes into play with:

- Boundary fences
- Roadside fences

The laws governing fences in urban areas are different from those in rural areas.

The cost of boundary fences are shared by the two parties.

Roadside fences should be stock proof as wandering stock could end up causing an accident. The farmer who owns the stock may find themselves in a legal battle or at the very least paying for restoration of property and increased indemnity insurance. Roadside fences should be post and batten or netting fences with at least nine wires. Any electricity should be on the inside preferably on an outrigger. If the electricity is part of the main fence warning signs should be visible.

Check the accurate location of boundaries before erecting the fences. Discuss plans with your neighbour

Soil Types

Soil types dictate

- The tools you use. (e.g. - crow bars in rocky ground).
- How easy it is to dig – wet, or soft and sandy, is easier than dry, stony ground, or clay.
- The size of the posts you use.

Soil type	Strainer Posts	Angle Posts	Line posts	Rise / Dip posts	Tools
Sandy soil	Strainer SED – 200mm 2.7m – 3.00m	SED - 200mm 2.1m - 2.4m	Quarter or half rounds SED 2.4	Quarter or half rounds 1.8m	Spade Post hole borer Post thumper
Silt	Strainer SED – 200mm 2.7m – 3.00m	SED – 200mm 2.4m - 2.7m	Quarter or half rounds SED 2.4	Quarter or half rounds 1.8m	Spade Post hole borer Post thumper
Peat	Strainer SED – 200mm 2.4m 2.7m	SED – 200mm 2.4m - 2.7m	Quarter or half rounds SED 1.8m	Quarter or half rounds 1.8m	Spade Post hole borer Post thumper
Stony ground	Strainer SED – 175mm 2.1m – 2.4m	SED – 175mm 2.1m	Quarter or half rounds SED 1.8m	Quarter or half rounds 1.8m	Spade Crow bar Post thumper
Clay	Strainer SED - 200mm 2.4m	SED – 150 -200mm 2.1m – 2.4m	Quarter or half rounds SED 1.8m	Quarter or half rounds 1.8m	Spade Crow bar Post hole borer Post thumper
Gravel	Strainer SED – 200mm 2.4m - 2.7m	SED – 200mm 2.1m- 2.4m	Quarter or half rounds SED 1.8m	Quarter or half rounds 1.8m	Spade Crow bar Post thumper

Not only do soil types affect the material you use, they also affect the pasture that is grown. Farmers will group similar soils (or similar pasture growing potential) into one paddock because this will enable them to make best use of the pasture that is grown, i.e.- even with similar soil, the north side of a hill will grow more grass than the south side because of the aspect. By subdividing these two, you can manage the pasture more efficiently.

Some soils are denser than others and can be compacted more tightly around a post when rammed. Some soils are damp to pack around the support. Other soils are too damp to pack around the support.

Location

Coastal areas, areas that flood, and areas that have heavy snowfall may require you to think about specific fence design.

In coastal areas the speed in which wire degrades is faster due to the corrosive action of the sea air and the minerals in the ground.

Conventional fences do not stand up to water and debris running through them. The debris doesn't pass through and tends to end up pushing against the fence. Therefore if an area floods the number of battens are generally reduced or not used at all otherwise the fence stands a good chance of being pushed over

If snow builds up against the high side of a hill fence, it can put a lot of pressure on the wires and posts.

Wind can also affect the integrity of a fence.

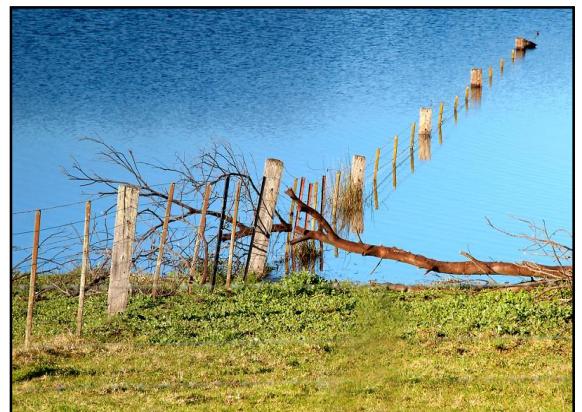

Budget

Some fences are definitely more expensive to put up than others. The more material (more wires, more battens) the more expensive. Not only do the materials cost more but the time to construct the fence is more so the cost of labour is higher too.

Netting is a cost effective way of fencing now however it does not suit all situations.

Tradition, fashion and personal taste

Just like clothes, the ideas and trends in fencing constantly change. Some farmers are very traditional in their work. This can have a huge impact on what they decide to do.

The two constants should be **containment effectiveness** and **longevity**

A drive in the country will see a range of fence types and trends.

- Totara strainers, posts and battens,
- Concrete strainers, posts and battens
- Half and ¼ rounds as line posts
- Wooden battens, wire and chain droppers
- Wooden and metal gates
- In line strainers, crimps
- Double loop knots, and tex brown knots
- 4, 5, 6 battens between posts. No battens at all.
- Wooden strays and concrete stays
- Posts – 4, 5, 6, or 7 metres apart
- Box strainer assemblies and diagonal strainer assemblies

The list is endless. These are just a few of the different materials and designs seen today. Some variances however cannot be seen at all such as:

- Foots
- The method a post is put in the ground – dug, bored or thumped
- Breast plates, stay blocks

Modern fencing practices are endorsed by the Fencing Contractors Association as best practice. Innovation and new materials have brought about many of the changes. National fencing competitions are good places to see these latest trends. Farmers sometimes are slow to change and prefer things done the way they have been done for a long time.

A contractor may try to persuade the farmer that a particular method is better than another, or that a particular material is stronger or more resilient but at the end of the day the farmer pays the bill. Although there are many 40 year old fences which don't follow all these latest trends still doing their job well, the new methods and materials are proven to make fences stronger, with less installation costs. Eg a swing foot versus a T foot.

Other planning considerations

- Material you have already at your disposal / existing fences.
e.g. battens, post and gates you have in storage.
- Maintenance costs
- Required life or service of a fence
- Availability of material
- Availability of skilled labour



Section 2

Fencing Material

Wire and batten

- Posts/strainers/stays / stay blocks
- Battens
- Wire
- Staples
- Permanent Strainers or joiners (optional)
- Anchoring material (Foods, Pegs)



Multi-wire (no batten)

- Posts/strainers/stays / stay blocks
- Wire
- Staples
- Permanent Strainers or joiners (optional)
- Anchoring material (Foods, Pegs)



Post and rail

- Posts
- Railing timber/nails



Netting

- Posts/strainers/stays / stay blocks
- Battens (Optional)
- Wife
- Netting
- Staples
- Permanent strainers or joiners
- Anchoring material (Foods, pegs)



Post materials

Concrete

- Concrete is very heavy, making both transport and installation more difficult.
- Concrete posts will not 'flex' under pressure like timber posts do, which means they have tendency to crack or break
- Concrete may regain popularity if timber becomes harder to source or more expensive, or technology improves its features.

There are a large number of concrete posts and strainers in use in existing fences all across New Zealand today. Concrete posts made during the war/depression are poorer quality as less cement was used. Concrete posts have their own types of staples, stays, foots, gudgeons, and wire attachment methods.



Steel

Also called standards, waratahs, flat iron standards, "T" sections, "Y" posts, star pickets or "staplelock" posts, metal standards are widely used as posts in the **South Island high country for permanent fences, and in both islands for temporary fences.**

- Typically, a steel standard could be expected to carry a sideways loading of about half that of a 115mm pine post before it failed (bent).
- Durability is a problem in high-salt or high ground acidity situations (e.g. in coastal situations).
- Un-galvanised steel posts tend to cause premature corrosion of wires.
- They can be put in the ground with a heavy object such as a sledgehammer or a driver
- Wire can be attached using a specially designed staple

Standards can also be used to anchor strainer posts. This is done by driving the standard into the ground at the correct angle and attaching it with wire to the post before hitting it home to ground level (possibly a few centimetres below ground). This helps stop the post from lifting or twisting

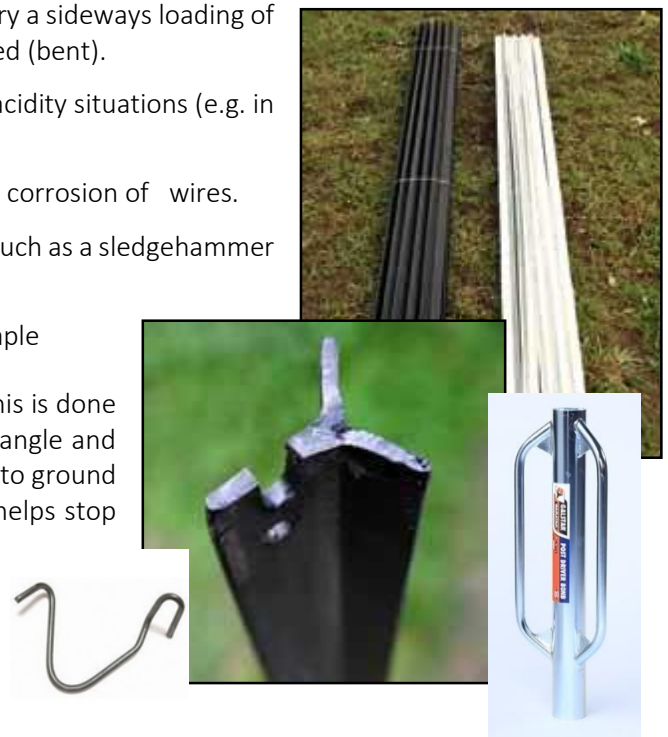

Timber

In pioneering times, while native bush was being cleared timber for fencing could normally be found within reasonable distance of a proposed fence line. **Totara** was the preferred timber - renowned for its durability (particularly in-ground) which is attributed to the high levels of protective oils in the timber itself. Many of the large Totara posts found in old fence lines have deteriorated at ground level but are still good condition both above and below ground.

Treated exotic timbers now provide most of the structural material for fencing. By far the majority of this is the Pines - Radiata and Corsican, with Douglas Fir also used. The demand for this product has created a very quick turnaround from planting to shop room floor with the growing and processing times becoming shorter and shorter. This generally sees a decrease in quality amongst posts and timber.

Timber treatment

H1 – H6 is the rating system for timber treatments which prevent rot and decay. Levels H1 and H2 are suitable for interior use only.

Any round wood or timber post which sits **on**, or **in**, the ground needs to be treated to **H4** or higher.

Treatment Level	Application (all suitable exterior use)	Typical Usage
H6	Marine Grade: Will withstand permanent salt water immersion.	<ul style="list-style-type: none"> • Marine piles • Slipways • Timber in seawater
H5	In ground. Structural Use. For timber exposed to the weather which will touch the earth/ will be sunk below the ground/ experience contact with fresh water/ be used in high risk or load-bearing applications.	<ul style="list-style-type: none"> • House piles • Retaining walls • Veranda supports • Fences (in set conditions)
H4	In ground. For timber exposed to the weather which will touch the earth/ will be sunk below the ground. Non-structural use only.	<ul style="list-style-type: none"> • Fence posts • Landscaping
H3	Above Ground: For timber exposed to the weather that will not touch the earth/is not sunk below ground level. Non-structural use only.	<ul style="list-style-type: none"> • Decking • Fence battens • Garden furniture • Trellis

Size and shape

Post shape

Posts are described by their shape.

- Round, half-round, quarter-round - these are called “Round-wood material

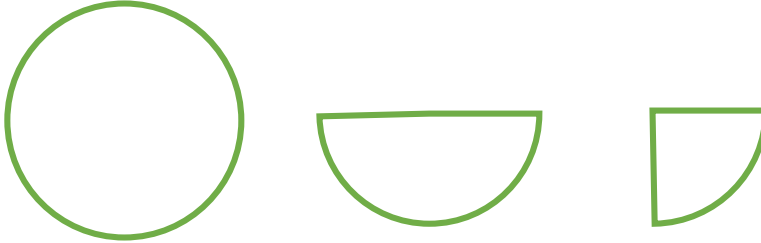

Post size

Size relates to *diameter* (SED – Small end diameter) and *length*.

Timber posts are graded on their minimum diameter.

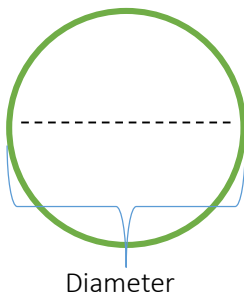

The diameter is measured and called the **small end diameters (SED)**. The smallest end is measured.

For half-round and quarter-round posts the size is denoted by **face width**.

A quarter-round is calculated by doubling the flat surface to get the diameter.

There are also ‘stay posts’ which are usually about the same diameter as a No.2 full round fence post, however they are the same length as a strainer post, (either 2.1M or 2.4M).

Round Posts

1.8m
2.1m
2.4m
2.7m
3.0m
3.6m



Half Rounds

1.8m
2.1m
2.4m
2.7m
3.0m



Quarter Rounds

1.8m
2.4m
2.7m
3.0m



Strainers

1.8m
2.1m
2.4m
2.7m
3.0m
3.6m



Strength of timber

The strength of timber depends upon a number of factors. The next important features are the **density of the outer wood**, and the presence of **defects**. Knots and other defects will reduce the strength of a post, but the effect is less severe than in sawn timbers. This is because the natural growth process generates nodal swellings around knots, which increase the local strength. When these are cut or planed off the result is a major loss of strength. However, providing posts are not machine shaved, but are merely trimmed and debarked, the nodal swellings retain much of their strength, and compensate for the presence of a knot.

There are other production techniques such as drying that affect the durability and strength of the post.

Choosing your material

When you go to buy your posts you should check what you're buying.

There are certain things to look out for:

- Make sure all the posts are uniform (all a similar size).
- Check out the knots. All mature high density wood will have knots in it which is ok. It is however important that there are none around the ground level mark. (600mm from bottom for 1.8m fence posts)
- Check their density. You can do this by looking at the amount of rings – are they close together or far apart. The further apart the less dense the wood is.
- Check you have the posts with the right treatment for the job you want to do.
- Check that there are no major bows, cracks, or splits.

Types of post

Strainer posts

The strainer is the most important post in the fenceline as it anchors the fence and takes the load of the line wires and sometimes gates. In both cases, the post needs basic strength so that it does not break and depth in the ground so that it does not overturn. In addition, post bulk or "meat" is needed in which to drill gudgeon holes and mortices.

Angle posts

Angle posts are placed at a part of the fence where a **change in direction** occurs. This change in direction puts additional pressure on the post, compared to a line post, therefore it is stayed. The main difference between angles and strainer assemblies is that the stay is **in the centre of the angle**, not in line with the wires.

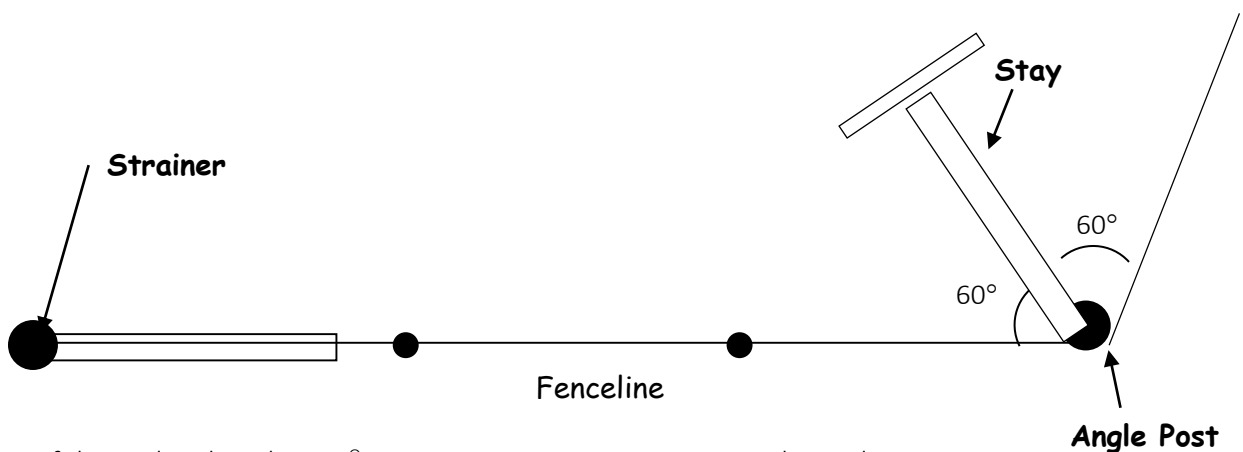

If the angle is less than 45°

Use 2.1m strainer as the angle post

If the angle is 45 – 90°

Use a 2.4m strainer as the angle post

Line posts – including dip & rise posts

Line Posts (Intermediate posts, running posts) support the wires of the fence and are located between the strainers and the angle posts. It keeps the fence up. If a line post happens to be on the top of a rise it is called a rise post and if it is in a dip or lower spot it is called a dip post. Posts are placed to give the bottom wire clearance from the ground.

These posts can be ¼ rounds, ½ rounds or rounds.

Stay

Stays are round, tanalised, posts. (Normally No2) Stay posts are used to help anchor a post against the strain of the wires. There are several methods of constructions depending on terrain, stock or personal preference. Together the stay along with a strainer and its anchoring system is referred to as the end assembly. This is because the stay is part of the fencing component that anchors the fence against the forces that the wires exert on the fence. Stays are also constructed on the angle posts as these also have forces exerted on them by wires.

The stay post should be free of imperfections such as large knots, bends or cracks, as this is a weak point and once strain goes onto the stay a break may occur at this point causing the whole end assembly to fail. This would in turn affect the whole fence.



Battens (or droppers)

Battens are usually 1.14 – 1.2m in length 50x50

Battens are used to keep the correct spacing between the wires.

Pine battens require an H3 treatment however, it is important to remember that although wooden battens are treated with preservatives they are not treated to be durable in the ground. Care should be taken to keep the bottom ends clear of the ground.

Totara battens are sometimes used or reused, which do not need treating. They too must be kept clear of the ground.

Recent fence designs either eliminate battens completely or reduce their number to one per post interval. Increasing the number of wires or using an electric wire compensates for the absence of battens. The traditional wooden batten or dropper still dominates but there have been a lot of variations in the system over the last 10 - 20 years

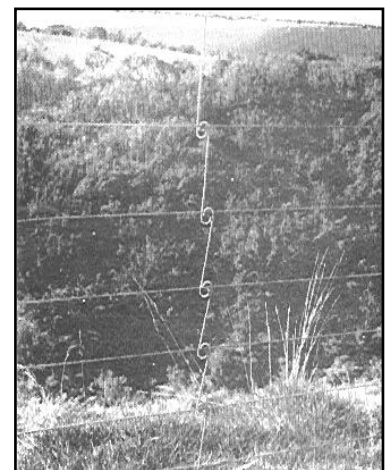

Other types of battens include:

- Chain
- Clip-on wires
- Galvanised steel strips
- Polypropylene string

The word dropper can mean different things depending on who you are talking to and what part of the country you are in. Sometimes a batten and a dropper mean the same thing. Other times it can mean a wire or fibreglass alternative to a battens

Timber railings

Timber is used to construct fence rails, floodgates and wooden gates.

- Rails are usually situated around gate ends, tricky corners or around trees.
- They are used for yards as they are solid and more visual.
- They are more decorative so can be used on road frontages or buildings.
- Many equestrian properties use post and rail as their main form of fencing.
- Rails are rough sawn, and usually Pine or Douglas Fir.



Timber sizes commonly used are:

- 125 x 32 (5x1¼)
- 150 x 32 (6x1¼)
- 150 x 50 (6x2)

There is special shaped railing timber also available that is often used in more decorative or domestic use. Half rounds can be used instead of timber rails but this is an expensive option.

To complete the timber rail fence, nails are necessary. 4" -6" galvanised flathead nails should hold most rails well. In high use areas such as cattle yards washers can be used with flatheads to give added strength to the structure.

If you are worried about rails coming off they can also be wired on. This is especially useful with cheaper wood as it tends to twist when it dries and may pull off the post. Use mild wire such as No 8 (4 mm)



Bolts & nails for use with timber

Coach bolt

Coach bolts can be used when putting on rails or making gates. Bolts give stronger holding than nails.

The square section at the top of the shank 'locks' the bolt so it cannot turn in the timber. This gives it good rigidity and strength. Most commonly used size is 10-12mm and all bolts for exterior use must be galvanised.



Nails

The general rule when choosing a nail length is to **choose a nail length 3x the width of timber you are nailing through**. Flathead nails should hold most rails well and are harder to pull through than jolt head nails. In high use areas such as cattle yards washers can be used with flatheads to decrease the likelihood of pull through and to give added strength to the structure. If you are worried about rails coming off they can also be wired on. This is especially useful with cheaper wood as it tends to twist when it dries and may pull off the post. Use mild wire such as No 8 (4mm). All nails for exterior use must be galvanised.

Wire

In New Zealand a large number of alternative wire types and sizes are available. Traditionally 4mm diameter mild steel wire (known as No8) has been extensively used, but it has largely been superseded by smaller diameter high tensile steel wire, which is much cheaper for the same strength. Both of these wires have a galvanised zinc coating which protects the steel interior from corrosion. Wire should be manufactured to NZ Standard 3471, and the buyer should always check this before purchase.

Wire is sold in coils that are measured by weight.

Wire Technology

New and improved technology means that wire is lasting longer and is stronger and more durable than it was 10 years ago. Today the coating of wire also includes an agent which aids in the self-repair of wire that is damaged slightly by wear and tools.

If the tension is increased, eventually a point is reached where the strain stops being proportional to the stress. It is around this point that the Yield Point of the wire is reached. This is when the tension (stress) begins to permanently damage the wire. At this point the wire will not return to its original length – it has been permanently stretched.

If the wire is continued to be tensioned, it will eventually reach a maximum stress level, called the Tensile Strength. After this point the wire weakens, and breaks

Breaking strains of the various types of wires can be found:

- In manufacturers publications, e.g. in product guides put out by wire companies.
- On the label of a new coil of wire. This is also called the Wire Mark, and is normally located at the lead-out end of the coil of wire

Mild steel wire

4.00mm (No 8), 3.15mm

Mild steel (also called 'soft' and *low-tensile* wire) has a lower '*carbon content*' than high-tensile steel. This makes it a softer steel that is easier to stretch and does not harden. As a result it is weaker, but it is more flexible and can be bent into shapes easily. It costs more to fence with mild steel and you must use a thicker gauge to achieve the same stock holding strength.

Traditionally 'soft' wire is used where fence posts are spaced closely or there is electricity as the main motivation for stock to stay behind the fence

<i>Stock containment:</i>	Good as long as fence design is good. Needs to have battens or be electrified. Cannot be tensioned as much as High Tensile, therefore stock are more likely to push through.
<i>Stock damage:</i>	Minimal damage to stock from the wire, unless wire ends are left protruding.
<i>Durability:</i>	Zinc Aluminium 2 Life - 130g/m ² and 4 Life – 260g/m ² surface areas The larger the wire diameter, the greater the long term durability. <i>It is more likely to stretch</i>
<i>Conductivity:</i>	Good. Larger diameter wire carries a greater current, but is not normally used due to cost.

High tensile wire

3.15mm, 2.5mm

High tensile wire is produced from steel rod that is forced (cold drawn) through a series of dies to reduce the diameter of the wire progressively until the required size is reached. The zinc coating is then applied (this is called *galvanising*). The cold-drawing process results in a hardening of the wire which increases its tensile strength. At the same time the material becomes more resilient (i.e. it tends to be harder to deform permanently) but also more brittle.

Smaller diameter wire is frequently used as it is cheaper, but with adequate strength. Otherwise, there is little difference.

High-tensile wire has a higher '*carbon content*' than mild steel/low-tension wire. The higher carbon content makes it stronger than mild steel and less likely to stretch (e.g. under stock pressure or falling trees). It is easier to snap because it doesn't bend as well.

While it is strong, high-tensile is also hard to bend and more difficult to cut and tie than mild steel/low-tension wire.

High tensile is much cheaper than mild steel wire

<i>Strength/containment:</i>	3.15mm – a high strength wire – good stock containment. 2.50mm – a low-strength wire – likely to break if cattle get caught in it.
<i>Risk of injury to stock:</i>	Low risk to stock (unless wire ends are left protruding.

(2.50mm poses a very low risk – will probably break if cattle are caught).

Durability:

Zinc Aluminium 2 Life - 130g/m² and 4 Life – 260g/m² surface areas The larger the wire diameter, the greater the long term durability.

Conductivity:

Good. Extensively used in electric fencing.



Fencing wire reference table

Diameter US GAUGE	mm	Minimum length 25kg coil (nominal weight)		Min breaking load kg force	Recommended tension kg force	Min Zinc Weight g/m ²	Min Zinc- Aluminium g/m ²
		feet	metres				
High Tensile							
16	1.60	5197	1584	220	80	200	
14	2.00	3323	1013	395	110	215	
12.5	2.50	2126	650	620	150	260	4 life 260 2 life 130
10.75	3.15	1339	408	835	200	240	
9.75	3.55	1053	321	1225	250	250	
8	4.00	830	253	1405	300	260	
Extra Heavy High Tensile							
10.75	3.15	1339	408	365	150	360	
Soft Wire or Low Tensile							
14	2.00	3323	1013	140	65	240	
12.5	2.50	2126	648	215	80	260	
10.75	3.15	1339	408	365	150	275	
9.75	3.55	1053	321	460	200	275	
8	4.00	830	253	590	250	290	
7	4.50	656	200	745	315	290	

Barbed Wire

Barbed is usually two galvanised wire strands wrapped together, with sharp pieces of wire sticking out every 100mm or so. Depending on the quality of the galvanising, the wire tends to rust earlier at the barbs, shortening its life. It is still sometimes used to prevent stock pushing their heads through a fence however the fence should be built strong enough to withstand the loads produced under these circumstances.

Strength/containment: A mid-strength wire, good as long as part of a well-built fence. Traditional barbed wire is often not tensioned as high as other wires, so stock can still push through the fence. Not as effective as electrification.

Risk of injury to stock: High – can damage skins, pelts, fleeces and can cause serious injuries to stock.

Durability: 20+ year life

Conductivity: It is illegal to electrify barbed wire.

Stainless steel

Good quality stainless steel does not rust. For this reason, stainless steel wire is used as a footing wire in fencing.

- used as footing wires (fencing for all stock types) because it is far more corrosion resistant than galvanised or zinc-aluminium coated wire
- for use when wire is in contact with the ground. Stainless staples should also be used with this wire.



Poly wire

- ribbons and strands of plastic woven together with fine stainless steel wire.
- used for temporary and semi-permanent electric fencing.'

Wire recommendations

Application	Recommended wire	
	High tensile	Soft/Low tensile
Electric fencing	1.60 mm, 2.00 mm, 2.50mm	2.50mm
Lead out wires (for electric fencing)	2.50mm and 3.15mm	
Coastal, corrosive situations	Zinc Aluminium Alloy coated–2.50mm, 3.15mm	Zinc Aluminium Alloy coated–3.15mm, 4.00mm
Brace wires in end assemblies	2.50mm, 3.15mm, 4.00mm	
Support wires in overhead irrigation systems	1.60mm, 2.00mm	
Training wires and overhead support wires for orchard applications	2.50mm and 3.15mm	
Tieback, artificial shelter applications and canopy support wires	3.55mm, 4.00mm	
Temporary electric and strip		1.60mm, 2.00mm
Tying and lacing wire		2.50mm
Horse containment		4.00mm
Footing wire		4.50mm

Wire Damage

Most types of wires are protected by a coating of either zinc (galvanising) or aluminium. This protects the steel core. If the coating is damaged the wire is weakened and the life span of the wire is reduced. Some of the wire produced today has a self-healing agent. Read the labels and the information that comes with your wire.

Care of wire

To help care for wire follow these simple guidelines:

- Always twist over the end of the wire when you cut the coil so as you can identify the right end to work from. If you don't have time or two hands free at the time poke the end into the ground and come back to it.
- Always run the coil out in the right direction and smoothly to eliminate tangling.
- Handle wire carefully when using it to prevent kinks, nicks or cuts on the wire.
- Keep wire away from corrosive chemicals. Tie coil tightly when transporting or storing.

Fabricated netting

Fabricated netting is made up of horizontal *line wires* with vertical *stay wires* (which are knotted to the line wires). The built-in stay wires replace the battens of a standard fence (making it quick and easy to put up).

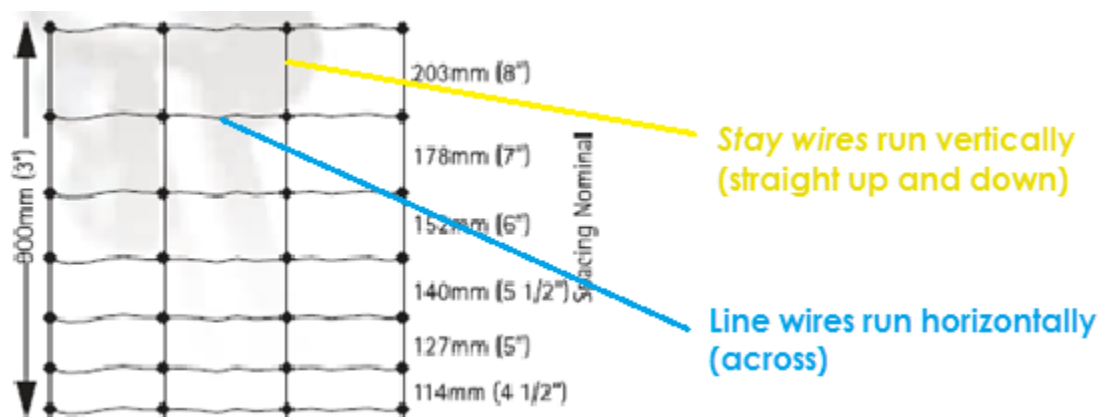

Netting may be made from the stronger high-tensile wire, or softer low-tension/mild steel.

Nettings are available in designs suitable for a full range of stock pressures and highly corrosive areas (e.g. coastal areas) Check manufacturer publication for details. Fabricated netting can be used in place of a standard *wire and batten* fence for most stock types.

Rust protection

Netting can be bought with *standard galvanising* (zinc only) or a *zinc-aluminium* coating. Zinc-aluminium coatings give 2 – 4 x the lifespan of standard galvanising used in the same situation.

Use/application:

Zinc-aluminium coated wire of the appropriate gauge should be used in coastal and other severely corrosive locations

(Check manufacturer materials on following pages for specific applications) – In general: deer, emu, ostrich, alpaca, sheep, cattle, goats, conservation & forestry blocks.

Strength/containment: Medium – high (depends on specific type)

Risk of injury to stock: Low

Durability: Galvanised – 20+ year life Zinc-aluminium coated – 40+ years (depending on location, handling etc.)

Conductivity: It is illegal to electrify barbed wire.

(See next page for more on fabricated netting)

Examples of fabricated netting available in NZ:

Tightlock

(Cyclone wire NZ)

Size Range Available:

Type	Description	Line Wires	Height (mm)	Stay Width (mm)	Length (m)
FAWN	A16 / 1900	16	1900	240	100
DEER	A13 / 1900	13	1900	150 / 300	100
	A11 / 1550	11	1550	150 / 300	100
TOP UP	A5 / 900	5	900	300	200
	A5 / 600	5	600	300	200
FIELD	A8 / 900	8	900	150 / 300	50 / 100
	A8 / 800	8	800	150 / 300	50 / 100
	A7 / 900	7	900	150 / 300	50 / 100

Applications:

Type

Deer	1900mm is the standard height. 1550mm is used for internal fences. A 150mm stay wire is often used for fawns and additional security on boundary fence and raceways, compared to a 300mm stay for internal fence and boundary as an economical alternative. Used for deer and ostriches.
Fawn	Used in deer fawning paddocks due to the tighter 240mm stay wire combined with the 89mm line wire prevents new born fawns slipping through the fence.
Top Up	Designed to make the extra height on top of a standard fence rather than replacing the entire fence. Used for deer and ostriches.
Field	Regional differences and stock types dictate the different line wires and total heights. Combinations with barbed wires or electric wires complete the barrier for stock. Used in high stock pressure applications for cattle, sheep, goats and pigs.

(Close up of the knot used to attach the *stay* wire to the *line* wire in *Tightlock* netting.)



Twinlock

(Cyclone wire NZ)

Size Range Available:

Type	Description	Line Wires	Height (mm)	Stay Width (mm)	Length (m)
FIELD	B8 / 900	8	900	150 / 300	50 / 100
FENCE	B8 / 800	8	800	300	100
	B7 / 900	7	900	150 / 300	50 / 100
	B6 / 700	6	700	300	100
LIGHT*	BL8 / 800	8	800	300	100
	BL8 / 900	8	900	150 / 300	50 / 100
	BL7 / 900	7	900	300	50 / 100
SOFT*	B5 / 525	5	525	150	100

* Soft uses a low tensile wire for the line wire. Light uses a 2.00 mm high tensile wire for the line wire.

Applications:

Type

Field Sheep, cattle, goats, conservation and forestry blocks

Soft Can be electrified break feeding. Lambs / docking

Light Low stock pressure, lifestyle and residential fences

(Close up of how the *stay* wire is wrapped around the *line* wire in Twinlock netting.)

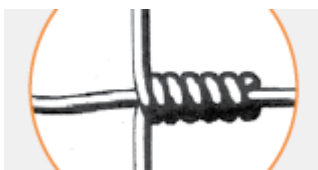

Rust protection

Wire, staples, nails, and bolts

Wire can be bought with *standard galvanising* (zinc only) or a *zinc-aluminium* coating. Zinc-aluminium coatings give 2 – 4 x the lifespan of standard galvanising used in the same situation.

The other term for rusting is 'corrosion'. Corrosion (rust) is a natural reaction between steel, oxygen, and water, but it is not good for fencing wire! ALL of New Zealand is classed as being a 'corrosive environment'. To protect steel from the environment (which breaks it down) we coat it with a protective layer of *zinc*. This process is called '**galvanising**'. The longer-term alternative to standard galvanising is wire that is coated with a *zinc-aluminium* alloy.

The thicker the coating of zinc the longer the lifespan of the steel: 20+ years is usually expected of fencing wire, and a Zinc-Aluminium coated wire has an expected life of 2 to 4 x longer life than zinc alone (giving you 40-year life in principle).

All steel intended for outdoor use should be galvanised.

Factors that speed up the corrosion of wire are:

- **poor storage:** coiled-up wet wire will corrode more rapidly than it does when spread out along a fenceline (because it stays wet). Storage near fertilisers, chemicals and corrosive materials will also corrode wire faster.
- **permanently wet conditions:** e.g. at, or below ground level. Galvanised wire is not recommended where wire goes into the ground. Use stainless steel wire.
- **contact with treated wood:** The copper in wood preservative reacts with the zinc, causing rapid corrosion. Allowing posts to dry out will reduce this problem but not overcome it completely.
- **salt air from the sea, wind-blown dust, corrosive gases in the air in volcanic /geothermal areas (e.g. sulphur):** All reduce the life of zinc coating. ALL of New Zealand is classed as being a 'corrosive environment'.
- **chemical contamination:** from drift or direct contact with fertiliser when transporting or storing the fertiliser.
- **frequent wetting (e.g. high rainfall areas):** every time the wire gets wet part of the zinc coating is lost due to the chemical reaction between the zinc and moisture. In high rainfall areas, the life of a fence is shorter than in a hot, dry climate.
- **nicking:** nicking is the damage to the wires galvanising from the use of tools, or by dropping tools on the wire. Pliers should not be used directly on the surface of the wire to hold it as they will scrape zinc off- thinning the protective layer, or exposing the steel underneath.
- **kinking and movement fractures:** care should be taken when hammering in staples that the wire is not accidentally hit.

Excessive bending and movement of wire weakens the wire and cracks the galvanising. Reusing old wire may not be a good idea if it has been bent and straightened

In farming, the environment is generally not too bad for fencing wire. If the air is clear and unpolluted and the relative humidity is low, then the loss of zinc will be very slow. In these areas, commercial wire products will last upwards of 20 years.

Staples

Types of staple

There are several different kinds of staples. The points can be finished differently and they may or may not have 'barbs'. These differences determine what they are suitable for.



Staples can be **plain shanked** or **barbed**. These are usually slice cut points. Less common are **diamond points**.

Plain shank

Use:

In 'green' timber – barbs cut the fibres, leaving the staple loose.

In tanalised timber – the copper corrode the barbs, leaving the staples loose (even galvanised staples).

In hardwood posts and battens – the extra resistance created by a barb would make the shank buckle when the staple is being hit in.

Barbed

Use:

In 'dry' posts – the barbs have better holding.

In pine battens

In soft woods.

Diamond point

Use:

When nailing into very hard timber – the point acts like a nail's point.

When fastening insulators – (the 'U' is wider compared to a slice cut staple).

Fibreglass rods

These rods have a special metal clip to attach them to the wires. These clip on to both sides of the wire and hold the rod firmly in place. There are also clips available for steel standards of varying types as well as hardwood battens and others.

Concrete posts staples

Concrete posts have staples which are driven through the post in holes that are precast. The staples are made of No. 8 (4 mm) wire and bend over in a groove in the back of the post.

Recommended staple lengths:

50mm – Posts

In hard wood you can use slightly smaller 40mm plain shanked staples (barbed staples in these situations buckle).

30mm – Battens

In pine battens use a barb, in hardwood battens use a plain shank. Batten staples are forced home to hold the batten firm

Corrosion protection for staples

To lengthen the 'life' of staples they are 'treated' to protect them from corrosion (rusting). To protect steel we coat it with a layer of zinc or a zinc-aluminium mix.

- **Hot-dip galvanising** coats the steel in a thick layer of zinc. This provides long-term corrosion protection. Hot-dip galv staples are suitable for use on all jobs. (In coastal or highly corrosive areas a *zinc-aluminium* coated staple has a longer life.) Hot-dipped steel is a dull grey colour with flecks of sparkle (because of the thick zinc layer).
- **Zinc-aluminium** coated staples have twice the lifespan of a standard *hot-dip galv* staple. Use to extend the life of the fence or in coastal and highly corrosive areas.

Staples must have the same level of galvanising as the wire they hold.

ALL staples or nails for exterior use and use in treated timber should be treated.

Nails

There are two types of nail commonly used on a fencing job.



Flat head

Flat head nails have a large flat head which is hammered in to sit slightly 'proud' of the surface of the timber. It is harder to pull through so gives greater holding power.



Jolt head

Jolt head nails have a smaller head. They are hammered in to sit 'flush' with or slightly below the timber surface. Because the head of the nail is virtually the same width as the shank they are easy to pull through the timber – their holding power is not as good as a flat head nail.

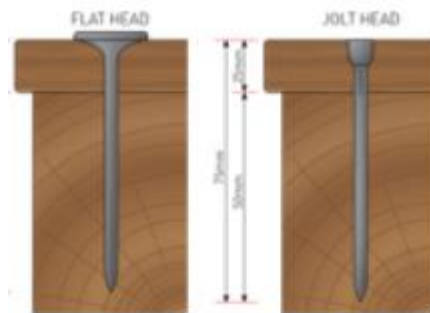

How nails sit on the surface of timber – proud (left) and flush (right)

Nail length

Choose a nail length that is **at least 3x the width of the piece of wood you are nailing through**. This is the general rule to follow and will give you good holding power.

Corrosion protection for nails

Nails for exterior use are *galvanised* to protect them from the environment. *Hot-dip* galvanising coats the steel with a thick layer of zinc. This provides long-term corrosion protection. ALL nails for exterior use and use in treated timber should be galvanised.

Permanent strainers

Also called in 'line strainers', these remain in the fence all the time. They are joined by two wires and can be tensioned using a handle in a ratchet manner, others just tension the wires (see top). These devices are commonly used on short strains (of up to 100m), as the wire can lose its strain. With these devices they can be strained up at any time quickly and easily. They are suitable for both electric and conventional fences. They can be used with most wires except barbed and aluminium.



Crimps/joiners

Crimps are metal 'sleeves' put on the two wire ends and squashed, to hold the wire tight. Specialised crimpers are required to squash the crimps properly. Crimping is stronger than any knot, and is applied when the wire is at the correct tension. No tension is lost after the wire strainers are removed. They are quick and easy to use, but you must have a proper crimping tool. The crimps has very good conductivity and are commonly used on electric fences. They can be used on all sizes of wire – you just have to make sure you buy the correct sized crimp.

To crimp wires together:

- Slide crimp sleeve onto the end of the fencing wire until 20cm of wire is showing past the sleeve if you want to finish by wrapping the ends otherwise 6mm will do.
- Push the wire to be joined through the opposite side of the crimp sleeve until 20 cm of wire is showing to finish by wrapping or 6mm if you are not.
- Open the jaws of the crimping tool and place the jaws over the end of the crimp sleeve
- Ensure that the jaws overlap the end of the crimp sleeve slightly and that the crimping tool is at right angles to the crimp sleeve. Compress the handles together Slide the jaws of the crimping tool along the crimp sleeve without leaving shoulders between crimps.
- Once the sleeve is completely crimped wrap the wire end around the wire 2.5- 3 revolutions and snap off. It is possible to cut the wire close without wrapping it

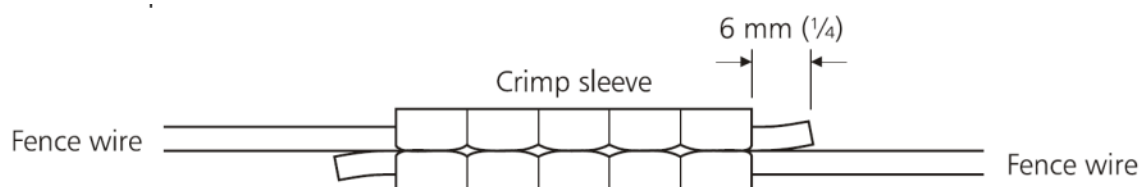

Rust protection

Wire, staples, nails, and bolts

The other term for rusting is 'corrosion'. Corrosion (rust) is a natural reaction between steel, oxygen, and water, but it's not good for fencing wire! ALL of New Zealand is classed as being a 'corrosive environment'. To protect steel from the environment (which breaks it down) we coat it with a protective layer of *zinc*. This process is called '**galvanising**'. The longer-term alternative to standard galvanising is wire that is coated with a *zinc-aluminium* alloy.

The thicker the coating of zinc the longer the lifespan of the steel: 20+ years is usually expected of fencing wire, and a Zinc-Aluminium coated wire has an expected life of 2 to 4 x longer life than zinc alone (giving you 40 year life in principle).

See page 36 for information on rust protection.

Anchoring Material

Pegs, Posts and breast plates are made from material that will not deteriorate in the ground such as tanned timber and concrete. Native timber such as Totara is also good to work with.

Fencers or farmers are able to utilise broken posts or old Totara posts or battens for this job. Stakes are usually metal standards as they do not deteriorate quickly underground.

Special shaped railing timber is also available which is often used in more decorative or domestic use. Half rounds can be used instead of timber rails but this is expensive.



Flood gates

Flood gates are used to keep stock from moving under a fence when it travels over a creek, ditch, small gully, culvert or hole in the ground.

It should be able to cope with the rising or falling water levels and it should not collect debris.

Returning to its original place when the water goes down is important.

They are never attached to the actual fence. This would put too much strain on the fence.



Floodgates are temporary.

Farmers tend to build them out of whatever is about. They are generally however made from wood or wood and iron.

Sometimes old gates are used. Posts, nails and wire are required to complete the floodgate

Gates

There are two choices of material when it comes to gates –**wooden/timber and metal**

- Timber/wooden gates are more expensive and heavier to work with, and metal gates are cheaper and lighter.
- The wood in the timber gates can weaken and break but they are easy for the farmer to repair whereas the metal gates do not break easily but they can bend.
- Repairing netting damage in a gate can be fiddly but with the right wire and netting, it is possible.
- Timber gates can be made to fit odd sized gateways but metal gates come in standard sizes although you can get them made to order.
- Timber/wooden gates can be of many different designs to suit different stock or personal taste. Metal gates come in a range of designs.
- Metal gates are covered in galvanizing.

A basic gate comes as heavy duty, standard, or economy, and in a range of sizes.

Sizes are in metrics but the length measurement usually equates to feet. In addition to the gate measurements below there are specialty gates for deer fencing and yards

Length	Height
2.44 (metres) / 8' (feet)	1.00 (metres) / 3' 3" (feet)
2.74 (metres) / 9' (feet)	1.00 (metres) / 3' 3" (feet)
3.05 (metres) / 10' (feet)	1.00 (metres) / 3' 3" (feet)
3.35 (metres) / 11' (feet)	1.00 (metres) / 3' 3" (feet)
3.66 (metres) / 12' (feet)	1.00 (metres) / 3' 3" (feet)
3.96 (metres) / 13" (feet)	1.00 (metres) / 3' 3" (feet)
4.27 (metres) / 14' (feet)	1.00 (metres) / 3' 3" (feet)
4.57 (metres) / 15' (feet)	1.00 (metres) / 3' 3" (feet)
4.88 (metres) / 16' (feet)	1.00 (metres) / 3' 3" (feet)

Section 3

Fencing tools – non mechanical

Spade

Spades come in all shapes and sizes. Handles come as shown here but others favour a T bar shape. The blade of the spade needs to be kept sharp. It can dull easily especially when digging in stony ground. The blade shape of fencing spades can also differ in width. Fencing spades often have a longer than normal shaft to help you dig those deep holes Even though a heavier spade may seem like hard work, ultimately it makes digging easier as it increases the strength of the downward motion and the amount of soil you loosen. Shovels are mainly used for moving large amounts of relatively loose soil or aggregate.



Hammer

The heavier the hammer the stronger you have to be but the easier it is to hit in those staples. Making sure that the head is roughed up with sand paper or on concrete is a good way to ensure that the head is less likely to slip off the staple when you hit it. The grip should be in good condition.



Ezepulls

Ezepulls make pulling out staples an easy task. Ezepulls now come with a crimping function. There are various models allowing you to crimp different size wires and cut wire as well as pull out staples. Moving parts need to be kept well oiled and clean of dirt and rust.



Pliers

Also known as staple pullers or fencing pliers.

This tool has an ability to hold wire, cut wire and pull out staples. A very handy tool. Care must be taken to ensure that the galvanising on the wire is not damaged when working with wire. Keep them well oiled and clean otherwise, they become stiff

© 2002, www.hooverfence.com



Wire cutters

The neatest way to cut high tensile wire is to snap it after completing tight loops, as opposed cutting it with wire cutters. There will however still be plenty of jobs for wire cutters when building a fence.



Rammer

The job of the rammer is to tightly press the soil around the post, stay or strainer when the hole is filled back in.

The consolidation of the soil around these parts of the fence are important to the integrity of the fence.

Rammers are heavy to help ensure that the soil is packed in very tightly.



Spirit level

A spirit level is used to plumb wires, rails and gates horizontally and strainers vertically. A strainer post should be perfectly upright or leaning backwards no more than 20mm.

Spanners

This tool is always handy to have close by. When fencing you can use it to tighten permanent strainers. They can also be used to tighten or screw in gudgeons to a gate post.



Crimpers (Ezepulls)

Crimpers are a specialise tool to use on wire crimps which join two strained wires together. There are several models on the market now that combine a variety of applications.



Chisel

A chisel is used when putting in a stay. The stay slots into a hole in the angle or strainer. This hole has been chiselled out to specifically fit the end of the stay post.



Chain strainers

These are wire strainers used to tension wire on the fence line. Once the wire is tightened and tied off wire strainers are taken off the wire to be used again. It is possible to strain up a whole fence with just two or three strainers but given the option it is easier to have a set of wire strainers. One for each of the wires. The chains and heads need to be kept well oiled and clean of dirt and rust



Permanent strainers handle

Permanent wire strainers give tension to the fence wires but unlike the type above these stay on the fence line once the tensioning has been done.

The tightening tool is used to wind the ratchet to tighten the wires to the correct tension.



Measuring tape

A valuable tool when planning your fence. It can be used to measure between fence posts or to get the right distance between gate posts. If you need to put up a set of rails this tool will also be handy to measure off and cut rails.

Spinning Jenny

This is a wire dispenser. It will run out one wire. Some models have several layers of spinning parts allowing you to run more than one wire at a time. Used correctly it allows you to run out a wire without tangling. Moving parts should be kept clean.



Brace & Bits

Still used to drill holes to insert gate gudgeons. You can use a heavy rechargeable drill but this old tool still does the job very well.

Rasps & Planes

Rasps are commonly used for fitting wooden handles to tools and to neaten wooden edges on stays and rails. The plane is also use to neaten rough edges.



Crowbar

The crow bar is used mainly when digging in stony or rocky ground. It can also be used in very hard soil to help loosen the ground you are digging before using the spade



Axe

Not often necessary when fencing however it may come in handy if you are fencing close to trees where you may encounter roots when digging.

Plumb bob

A plumb bob does the same thing as the spirit level when measuring vertically. It is cheap and easy to carry around.



Elastic measure

The elastic is also a cheap but very effective tool to ensure your batten spacing are spot on every time. The elastic with regular marks guarantees even spacing no matter how far you stretch it. It is therefore very adaptable, being able to be used no matter what your post spacing are.

Wire space marker

A handy tool that will ensure regular spacing between your wires on every post for the entire fence line. An old shovel handle or similar piece of wood will do. Some fencers add these markings to their rammer.

Tension meter

The tension meter measures the tension or strain on the wire. This is important to ensure the wire is not stretched but is tight enough to be stock proof. Over stretching a wire damages the wire permanently causing it to lose its effectiveness



...and a pencil

It is hard to build a fence without a pencil although some use a nail to make marks on the wood when their pencil has fallen out of their pocket.



Mechanical Tools

Chainsaw

A chainsaw is often used in fencing for erecting strainer (stays) assemblies and angle posts. It should never be used to cut the top off fence posts. It should always be used with all of the right protective gear no matter how small the job.



Refer to the chainsaw manufacturers handbook regarding maintenance and enrol in a chainsaw course to learn how to use this potentially dangerous piece of equipment safely.

Post hole borer

These are not light machines so should be used using the correct lifting techniques and with appropriate safety gear such as ear muffs and sturdy footwear.

- The augers come in different sizes relating to the job or post to be used.
- Refer to the manufacturer's handbook regarding maintenance
- There are also tractor mounted models



Post thumper

The Post Thumper is mounted onto a tractor or bulldozer. The basic principle is that the machine holds a post in place and then uses a heavy weight called a monkey dropped from a height to hit the post into the ground.

There are plenty of opportunities for accidents to happen, the most obvious one being crushing between the falling weight and the post. More expensive models give features that make them more manoeuvrable and versatile. This also allows for work in more difficult environments.

- There is definitely a skill involved with using this piece of machinery well.
- Refer to the manufacturer's handbook regarding maintenance

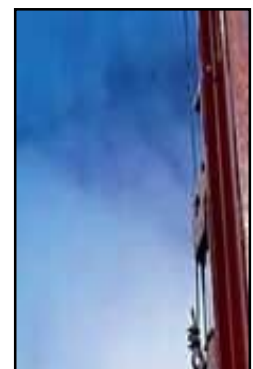

Maintaining Tools

Keeping tools clean is the best way of keeping them in good condition. This means giving them the once over with a cloth, wire brush or a hose down or shake at the end of the day to get rid of the excess dirt etc.

Other tools such as chisels and spades and saws have sharp edges which need to be cleaned regularly and sharpened when they become dull. Keeping chisels and saws with their covers on prolongs their sharpness.

Handsaws are best sharpened by a professional. Chisels can be sharpened using a sandstone to take off the edges. A professional sharpen on an annual basis if you use them a lot would keep the chisel in really good condition. Fencers often use file or grinder to sharpen their spades.

How you transport your tools can have an effect on how often you need to sharpen your tools. If you throw all your tools on the back of the ute where they can move about and hit each other and become damaged or blunt.

Some tools such as tension measurers, ezepulls, pliers etc. with moving parts require oiling on a regular basis to keep them operating well.

Always remember to

- clean regularly
- cover sharp edges (where applicable)
- sharpen regularly (where applicable)
- oil regularly (where applicable)
- carry and transport in an orderly and secure fashion
- use the right tool for the intended job.
- store the tool in a dry place when not in use
- motorised tools (chainsaw, hole borer and post rammer) require additional maintenance such as additional cleaning, filters etc. plus oiling and greasing.

Safety Equipment

Ear muffs

To be used in conjunction with machinery. e.g. chainsaws, borers, thumpers or tractors. Make sure that they are in good order.



Sturdy steel capped footwear

Boots or gumboots that are steel capped are essential when using powered equipment and for when using heavy or sharp equipment in case they are dropped on the feet. They should have a good tread on the sole.



Safety goggles/glasses

These are to be worn when doing wire work. Wire flicking into the eye may cause permanent damage and the loss of sight. Staples can also flick up towards your face and eyes so glasses are also used when stapling.

Glasses are also good for protecting your eyes from damage in summer.



Chaps (chainsaw use)

Necessary for when using the chainsaw even if it is just to make a couple of small cuts.

They must not be damaged and should fit correctly.



Gloves

Gloves made out of leather or similar tough material are useful when working with barbed wire. They can however be used when doing other jobs such as rolling up wire although may interfere with some of the other work that is done when fencing.

Hands usually toughen up when doing a lot of fencing. Where wire work may seem difficult to start with, your hands become accustomed to it.

Weather appropriate clothing and protection (sun hat, sun screen, water)

In the summer it is vital for you to be protected from the sun and its affects. Regularly applied sunscreen is advised. A brimmed hat when not wearing a helmet is good at keeping the sun from your face and neck.

Similarly in winter it is a good idea to keep well covered to keep body temperature at a good level. If your body temperature drops too low you will begin to feel the effects of hypothermia. Woolly hats and wet weather gear are essential.

It is also important to remain hydrated with water and to ensure that you are also eating well. Poor nutrition and hydration can lead you to make poor decisions which could affect your health or performance. There are some jobs in fencing like putting in a strainer that you only want to do once!!



HAZARD	TO WHOM	POSSIBLE INJURY	CAUSE OF INJURY	PREVENTION
Wire and staples	Stock	<ul style="list-style-type: none"> Cuts & pelt damage Poisoning & ruptured stomach 	<ul style="list-style-type: none"> Protruding wire Poorly tied knots Stand on staple and injure foot Eating foreign objects (e.g. staples wire cut-offs) 	<ul style="list-style-type: none"> Finish joins/knots better. Pick up all staples Bury metal rubbish or take it with you Leave a clean and tidy fencing site.
	People	<ul style="list-style-type: none"> Cuts, loss of an eye 	<ul style="list-style-type: none"> Wire springing back Someone else letting the end of the wire go. Wire breaking while tensioning Miss-hitting a staple that flicks up into face. 	<ul style="list-style-type: none"> Wear safely goggles while fencing. Know the maximum tension that can be put on wire Always dig the end of the wire into the ground, instead of letting it go.
Tools	People	<ul style="list-style-type: none"> Cuts and blisters Muscular and back injuries (post hole borer) Hearing damage Severe laceration & amputations 	<ul style="list-style-type: none"> Poor technique Bash fingers on posts when ramming, hit fingers when stapling. Catch fingers in tools (e.g. pliers) Poor technique/posture Over-use Lifting/moving heavy tools and materials Working with powered machinery, without hearing protection. Kickback from a chainsaw Not wearing safely equipment 	<ul style="list-style-type: none"> Learn proper operation of tools Pay attention. Wear gloves where possible Avoid over-use. Alternate jobs with someone else. Learn correct operation. Use lifting devices where possible, or ask for assistance. Wear approved ear muffs Ensure each machine has a properly fitted exhaust, or silencers are used. Wear safely chaps, goggles, footwear, muffs. Know the correct cutting techniques.
Power lines	People	<ul style="list-style-type: none"> Electrocution 	<ul style="list-style-type: none"> Working under power lines, and wire springs up and connects with the lines. 	<ul style="list-style-type: none"> Be aware of what is above and below you. Be particularly careful when working with wire, near power lines.
Weather	People	<ul style="list-style-type: none"> Muscular, strains, sprains Electrocution 	<ul style="list-style-type: none"> Slipping while fencing on wet, slippery hill country Hit by lightning while fencing in electrical storm 	<ul style="list-style-type: none"> Avoid fencing in these conditions Stop fencing until storm is over.
Fence	Stock	<ul style="list-style-type: none"> Death 	<ul style="list-style-type: none"> Poorly designed fence, stock smother each other. 	<ul style="list-style-type: none"> Carefully design fence lines.

Section 4

Fence Components

There are several areas that must be mastered to build a fence

End assemblies



Intermediate support

- Intermediate post
- Rise and dip posts
- Angles
- Battens



Wire



Gates/ flood gates



End Assemblies

Strainers

An end assembly is where you position your Strainer post. It is found at the end of a fence line. It anchors the fence and they are considered the most important posts in the fence line.

They carry the strain of the fence and support any gates if necessary. Getting the correct position of the strainer post is important and warrants taking a good look at the surrounding terrain. The terrain and soil will dictate the type of end assembly you construct.

You should also take a good look at the quality of your post. They should be straight and free of weak spots that could cause problems when the post is put under strain.

Generally strainers are double the fence height (except for deer fences) but as discussed earlier the type of soil they are being put into will have an influence on this rule. A SED of 200mm is a good size for most situations.

They are usually put in at a 90° angle to the ground however some fencers lay the post back lightly against the strain so this allows the post to move forward slightly when the strain goes on leaving it in the right position

There are four major types of end assemblies

- Horizontal stay assembly (or box stay)
- Diagonal stay assembly
- Tie back assembly
- Breast Block assembly

The tie back is more likely to be used in horticulture and the breast block assembly, more likely to be used in the erection of an electric fence.

The shapes and sizes of end assemblies vary greatly. Which type you use depends on a variety of reasons. E.g. Personal preference, type of fence, ground and terrain conditions, soil type etc.

Despite the different types the purpose of an end assembly remains the same - to provide an anchorage point for the line wires. It needs to be strong and stiff. It should remain secure to all the strain and pressure that is exerted on it by straining the wires, the weight of gates and the direct pressure of stock.

When the wires are strained up they are exerting a force which pulls the post over. The idea of an end assembly is to exert an equal force or pressure in the opposite direction so that the post remains firm and straight.

Diagonal Fence Assembly

This is a common end assembly option, but it must have room and ground levels that suit the stay block.

The foot, stay block, and stay have parts to play in keeping the strainer post in the ground.

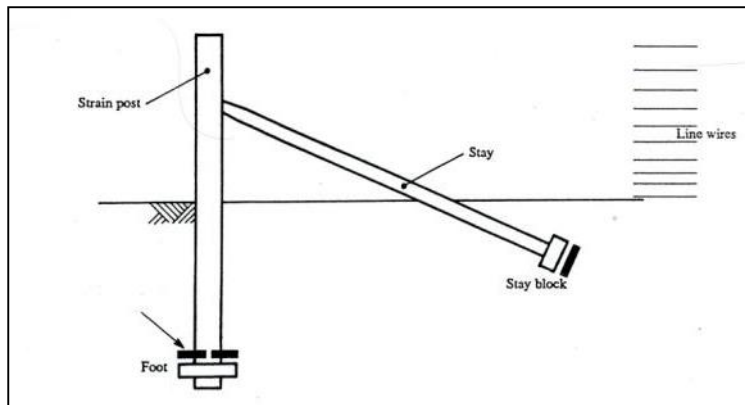

For every pressure inserted on the fence system there should be an equal pressure in the opposite direction. When this happens everything should stay in place

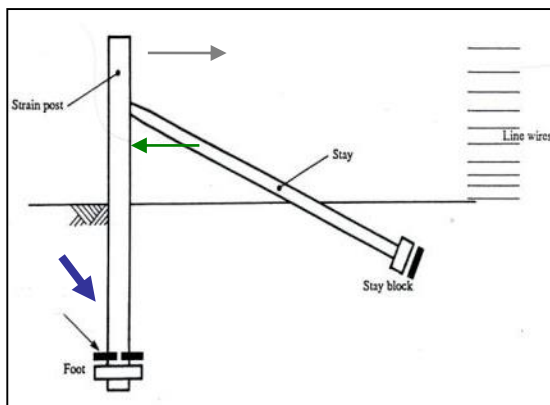

The pull of the wires pull the post in this direction



The stay block holds the stay in place so it can resist the pull of the wires

At the same time though the stay is pushing against the strainer, so we put a foot on the post as well to prevent it lifting



Horizontal Stay Assembly

This is another commonly used end assembly. It is also designed to equal the force exerted by the wires so that the strainer post remains firm.

There are a few extra pieces to the system of keeping the strainer post firm and in the ground. The Inside post, horizontal stay, (1.5 times the amount of post out of the ground) diagonal tie and the foot are important pieces of the construction that you must get right in order for this assembly to work.

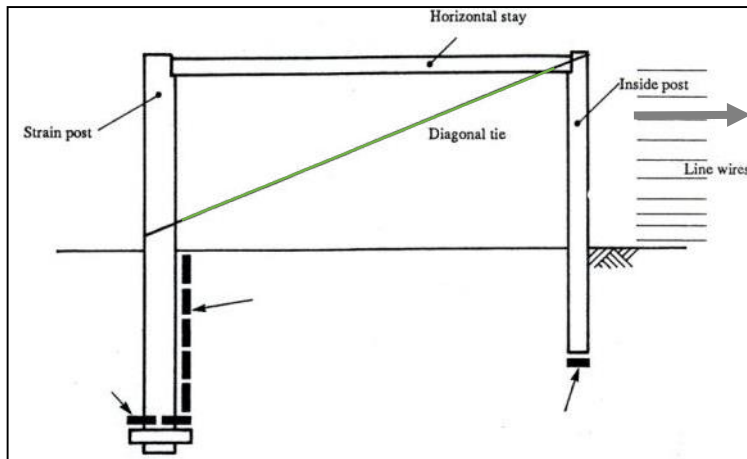

The pull of the wires will try to move the posts in this direction. →

The horizontal stay is being pulled with the posts in this direction but the **horizontal tie** is bracing it so that the structure is remaining square.

Even though a foot is shown there is no upward lift on the strainer. A breast plate however would help to stop the pull of the post.



The other two end assemblies are more commonly found in horticulture and permanent electric fences. You can see by their construction that there is equal pressure exerted against the strain of the wires to keep the post in place

Tie back assembly

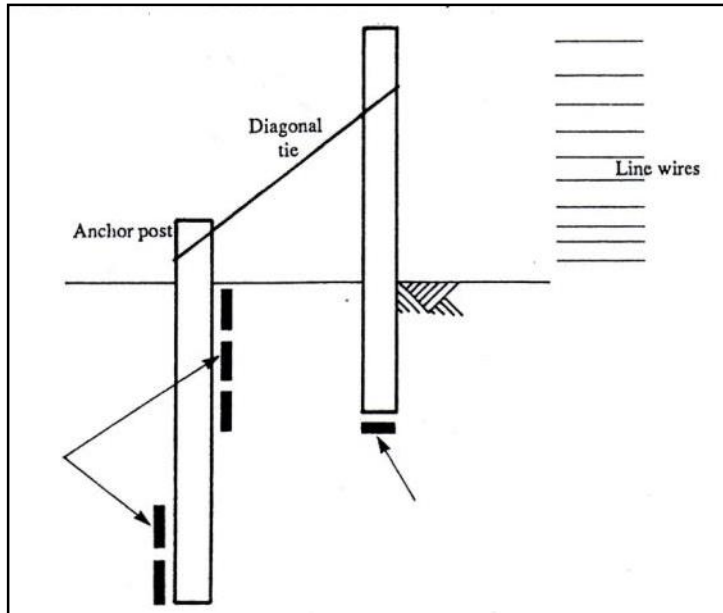

Breast block assembly

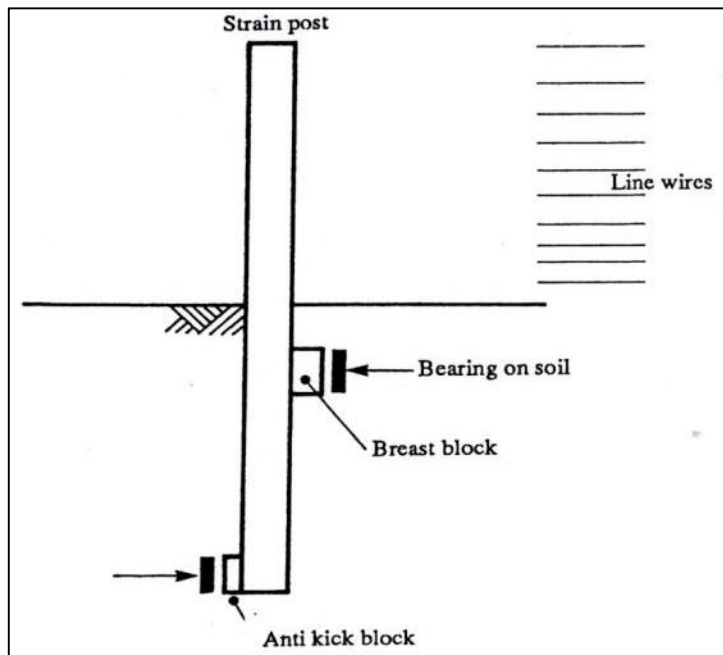

Failure of end assemblies

There are many reasons why an end assembly does not stay in place.

Material

- The material you use could be faulty, a weak place in the wood. (knots, cracks etc.)
- If the wrong material is used it will also cause a problem (e.g. the foot is too small). Some soil (sandy, boggy type soils) may require larger posts, deeper posts, larger foots, larger breast plates and big pegs.

Construction

There are many places during the construction where you can get it wrong.

- Failure to put all parts into the system (e.g. leaving out the foot).
- Putting parts in the wrong place (e.g. connecting the stay to the post too high or too low putting the foot too shallow).
- Incorrect technique in securing parts to each other. (e.g. the footing may be incorrectly fixed, the hole where the stay is attached to the strainer may be off centre or too shallow, tieback wires may have slipped) If line wires are too much to one side of the post it may cause posts to twist in the ground.
- Incorrect sizes (Posts too high – not in the ground far enough, anchor posts too short, horizontal stay too short).
- Any one of these points may cause the posts to break, bend, lift out, twist in the ground or move forward. In most of these cases the wires will lose their strain and the integrity of the fence is compromised
- A good end assembly will stay in place whether the soil is put back in the hole or not. Therefore the ramming of a post only has a minor effect on the integrity of the end assembly.

How to put in an end assembly (All types)

Check the soil

First job – select the site for the end of the fence then look at what type of soil you are dealing with to select the right materials and establish which type of end assembly will suit the position.

- **Strong soils** include silts and clays
- **Medium soils** include sands, silty sands and those silts and clays that have consistency in between strong and weak soils
- **Weak soils** include silts, clays and loams with the consistency of soft putty.

The soil type will let you select the correct Anchor – stay block or breast block

Post selection

For any type of end assembly a strainer post is used. **Strainer posts** are normally made of wood with a minimum small end diameter (SED) of 200mm, and length of 2.4 – 2.7m.

Anchoring System

All Strainers are either anchored or braced against the forces of the wires.

All Angles and dip posts need to be footed in the ground to ensure that they don't lift or rotate. (The exception is if they are driven)

There are two main ways of footing a post. The swinging foot is becoming the more popular way however the pegged system is still used a lot and is also very efficient at anchoring posts

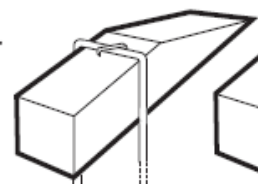

Swinging Foot

- The foot consists of a piece of ground treated timber with a 4.00 mm or 3.15mm heavily galvanised stainless steel wire stapled to the underside of the foot
- The wire should be at right angles to the foot and well-shaped.
- Bend the wire around the foot and neatly wrap the short end around the long wire using a pair of pliers. The tails should be left long to avoid unravelling.
- Place the foot beside the strainer in the bottom of the hole with the staple side sitting flat on the bottom of the hole. Do the same with a second foot on the other side of the hole.
- The wire that extends from the foot is wrapped a half turn up the post in the direction of anticipated movement. This will help avoid lifting and rotating. E.g. if the line wires leave the right side of the strainer the left foot wire should be fixed on the right side of the strainer.
- Staple the wires clear of the ground to avoid corrosion.
- Place a block of timber across the top of both feet at the back of the strainer.

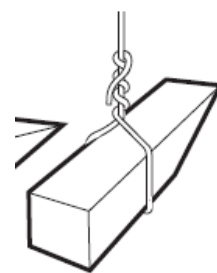

- Use one staple to staple the foot wires to the post approximately 150mm above ground. The staple should be 45° across the wire and driven in firmly. Complete the stapling (see diagram) on both foots.
- Ensure the foot is still in place and commence to fill and ram in the strainer or post.

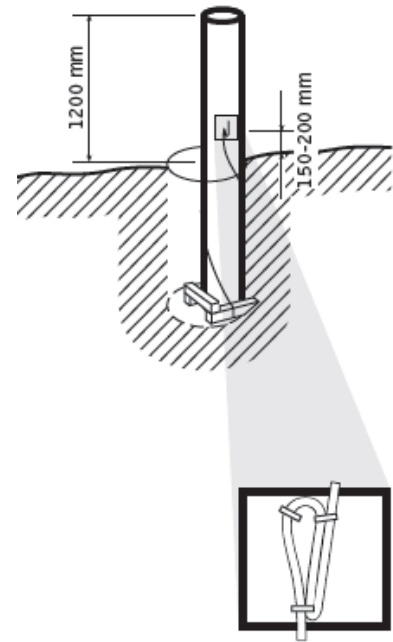

Mortice or T Foot

As with the swinging foot the wood used should be ground treated or a native (e.g. Totara) which will not rot below ground. There are also pre-cast concrete foots available. In this system, a foot is located near the base of a post. It is positioned at the front of the posthole; the same side as the wires. It helps to stop the post moving upwards. This placement of the foot at the front is a new trend which will take some time to be adopted by a lot of farmers and fencers. In the past it has been placed at the back.

Even though this job cannot be seen from above the ground, it is a **very** important component of the fence that must work well for the fence to have any integrity

Because it is below the ground it is hard to fix so getting it right when it is installed is essential. The foot is attached to the post approximately 100mm of post remaining under the foot. This is attached prior to putting the post in. It is wired on but because some wires may deteriorate it is also checked into the post. The checking can not be too deep as this will affect the strength of the post.

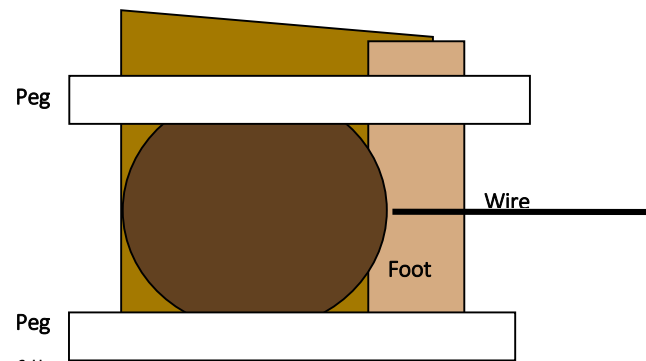

Once your post and foot are in the hole and before you begin to fill in the hole add the pegs which are placed over the foot. They are generally longer than the hole is wide so they have to be put in on an angle and rammed into place. Once these are in the hole can be filled and rammed.

Today a lot of the posts and strainers that are put in are thumped in. This means that they cannot be footed. Because they are rammed they are very tight in the ground but a fencer can still do several things such as pegging down beside the post to help secure the post in position ready for when tension comes onto the wires.



Horizontal Stay Assembly

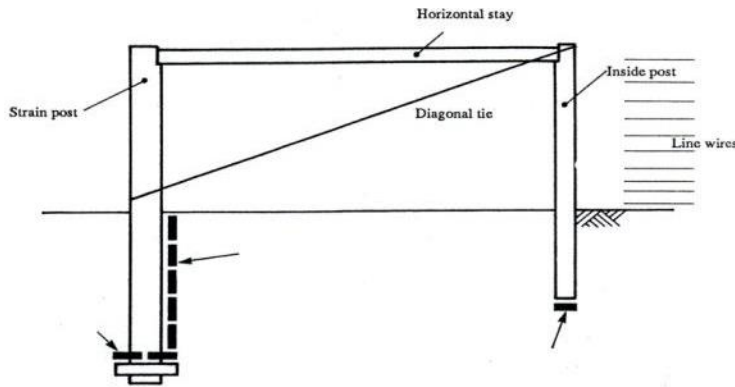

1. Dig the hole for the strainer post. Put the strainer to a depth of 1.2 if using a 2.4 post. The smaller end of the post should be at the top
2. Foot the strainer post and ram in firmly. (How to 'foot' a post is covered later).
3. Run a guide wire to the next assembly (this is so you can get the inside post in the right place).

Wire should be placed off centre as indicated in the diagram (right).

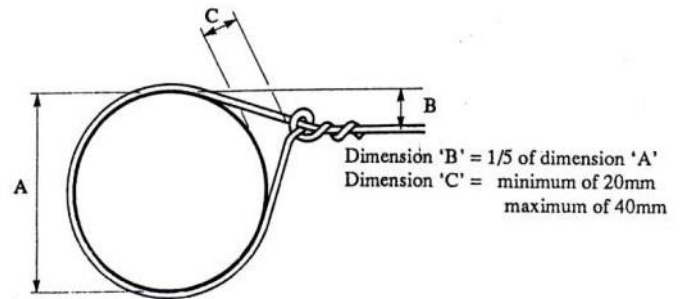

4. To find out where to dig in your inside post lay the stay down beside your strainer. Place the LED (Large End Diameter) or big end of the stay so that is equal to half way on the Strainer Post. Mark where the SED (small end diameter) or small end of the post is. This becomes the front of the post hole for the inside post. *See diagram below.*
5. Dig your hole for your inside post and ram in firmly.

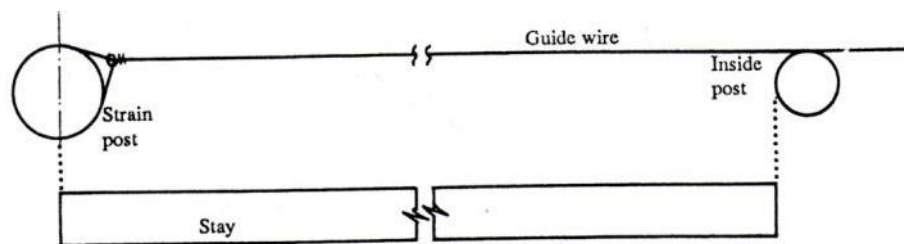

6. You have to install the stay now so that it does not interfere with the wires and it must be rebated into both posts so that it does not sit above the height of the posts.

7. You can rebate into your posts up to 20mm

8. Your stay should be central to the posts and not interfere with the wires. It should be located between the first and second wire if possible.

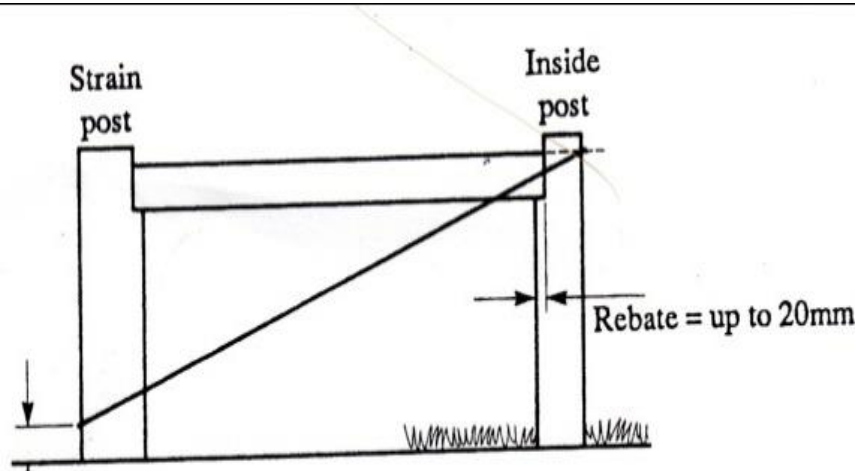

9. Now you must install the tie wire. This is outlined in detail in the wire section

The finished end assembly sees the fence wires attached to the strainer and the stay and inside post together with the tie wire stop the strainer from being pulled over when the fence wires are strained tight.

The Diagonal Tie

You have to **brace** the Horizontal Stay, this is done with wire.

1. Take a part coil of high tensile wire and place one end into the ground about 200mm forward of the strain post
2. Fix the wire to the strain post approximately 100mm above the ground. Do not drive the staple home (Staple 1)
3. Pay out the wire around the strain post and inside posts three times, stapling the wires each time but not driving the staple home (staples 1,2,3) Each successive loop should be slightly higher up the post in line with the stay.
4. Take the end of the wire out of the ground and attach to it the handle end of the chain grab wire strainer.

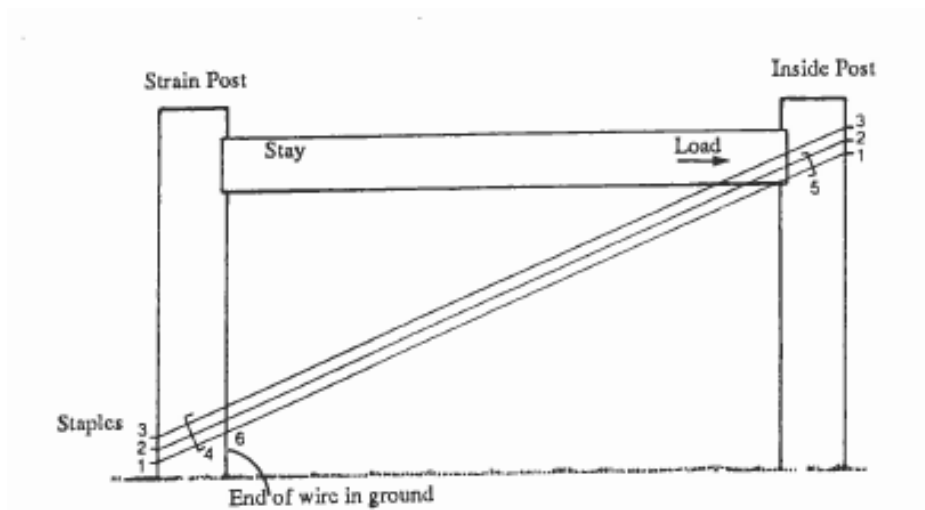

5. Attach the chain grab end to the part coil of wire. Do not cut the wire at this stage.
6. Work the strainers until the wire is firm
7. Holding one side of the loop of wires, (i.e. 3 wires) work them back and forward a few times to ensure that the wire is not binding at any point. (*The wires will bind if they cross over at any point*).
8. Place staples (staple 4) to cover all the wires on either side of the strain post. Do not drive the staple home
9. Place staples (staples 5) to cover the lower two loops on either side of the inside post. Do not drive the staples home.
10. Work the strainer until the wires are firm. They do not have to be tight. Usually a crack of about 3-4mm will appear at the front of the posts.
11. Drive the staples (staple 4) so that they just bind the wires on either side of the strain post. These will be eased out slightly later
12. Carefully remove wire strainers
13. Remove the staple (staple 3) at the top of the inside post.
14. Cut the coil end of the wire approximately 200mm forward of the post.
15. You will not have two short ends of wire at the base of the strain post. Wrap these ends around the front of the post and drive staple 6 home
16. Bend the bottom wire back on itself and slightly upward and the top wire back on itself and slightly downward so that they are looped together with the staple at the centre. Trim the wires to 100mm from staple 6
17. Bend approximately 30mm of the wire ends at right angles and drive them into the post. This will act like a staple and leave no untidy ends
18. Ease the staples (no 4) so that the wires can work, i.e. so that all wires will be under equal load.
19. Ensure that staples 1-5 are driven so that they are just free of the wires

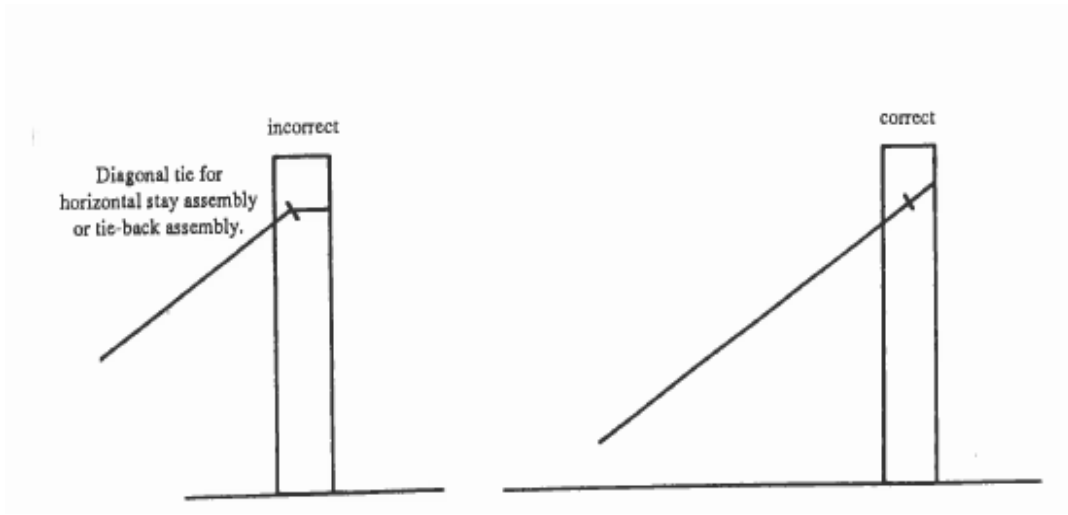

Diagonal Stay assembly

Steps 1 and 2 as for Horizontal Stay Assembly.

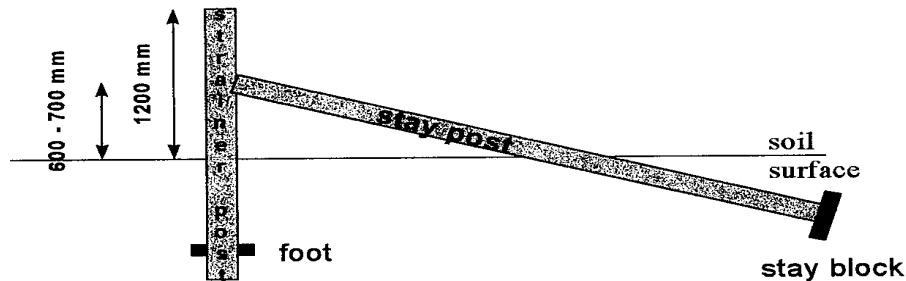

3. Take your stay post and mortice the end as this will be fitted into the Strainer post. This involves shaving off one end of the stay so that it has a square end

which can be morticed into the strainer post. This is often done with a chainsaw. The amount of squaring off ranges between 50% and 70% of the SED

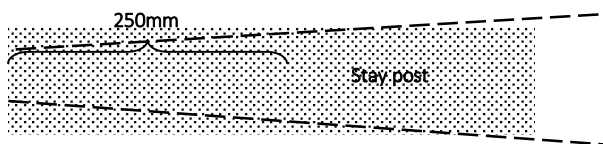

Four slices are removed from the post to reveal a square end.

If using a chainsaw safety gear should be worn. It is important that your stay post is well secured before attempting this job with a chainsaw.

4. Install the stay block, this is dug into the ground. The distance away from the strainer is very important. You can determine where to dig by setting the mortice into the post and making a mark where the other end of the stay post ends.

The length and width of the stay block should suit the ground conditions and the wire loading. (5 wires will not exert the same force on a post as 10 wires) The depth that the block is set is also important. It must be deep enough so that it will

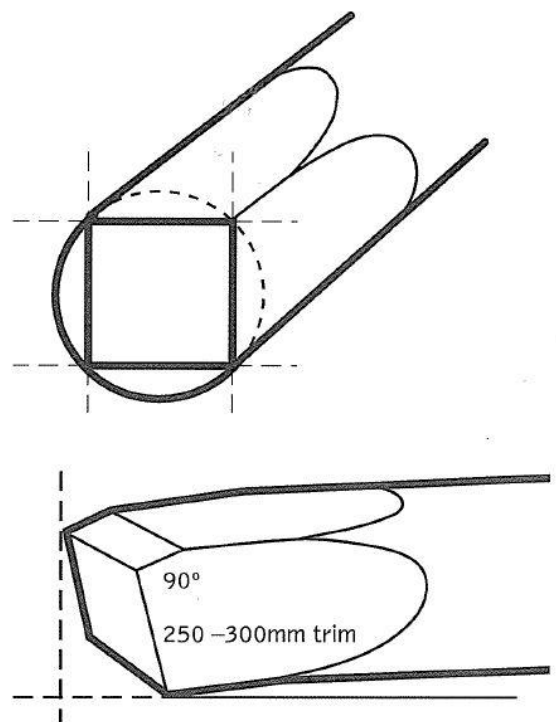

bear against the soil. At least 50mm below ground level.

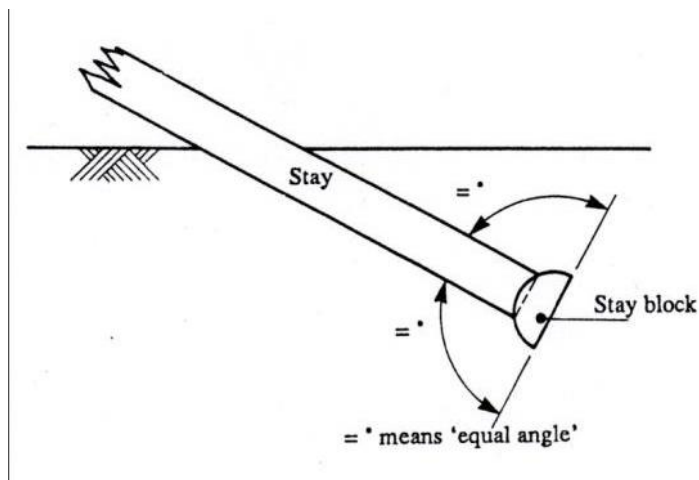

Part of a half round post makes an excellent stay block. The rounded face is the part that will come in contact with the stay. It is a good idea to flatten off the middle part of the rounded face where the stay comes in contact. This gives more contact area. To do this you can run the chainsaw back and forth along, the part where contact is made. The flat side of the stay block faces away from the stay to push against the soil.

5. Chisel out a notch in the strainer that matches the square end that was cut from the SED of the stay. The stay should join the strainer at a place less than half way up the post.
6. Fit the stay into the strainer. The other end of the stay is then prised into place against the stay block. It should be a very tight fit. You can use your spade blade to ease the end onto the stay block in the same way you would use a shoe horn. The fit should be so tight that it pushes the post a little (5mm) off vertical.



To finish off the assembly the top of this strainer post has the edges cambered.



The sizes for stay block anchors (a conventional 8 -10 wire fence using 2.5HT wire) are recommendations and may not apply to all situations.

SOIL STRENGTH	SOIL	ANCHOR SIZE (half round)
	Strong soils	0.9m x 200mm
	Medium Soils	1.2m x 200mm
	Weak soils	1.8m x 200mm

The importance of a good assembly is evident mostly when it fails as seen in the picture here where no stay block was put in because the farmer was only attaching five electric wires to the post. It didn't take long for the strain to pull the post over.



Ramming in the soil

The tool used for this is called a rammer. It has a heavy 'club end which can reach down the side of the post when it is in the ground and compress the soil tightly around it.

Once your hole is dug to the right depth and your post is sitting in the hole – the face against your established side - you can put a small amount of soil back in the hole. *At this point you will be pleased that you kept the soil close and in a tidy pile.*

Use the rammer to ram the loose soil at the bottom of the hole. Check that the post is straight and continue to put soil in, ram and check for straightness. There is no point ramming the top of the hole well if the bottom is not tight. It should be tight all the way from the bottom to the top. When you get to the top, ram the soil you first took off around the top and stand back to admire your work!

If you are ramming in a dip post or strainer post you will first have to foot it before filling the hole back in

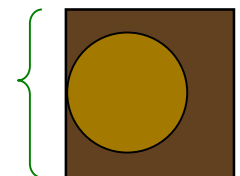

Your first cut with the spade



Angle posts

These are the next posts to be dug in after the strainers are in place. They are positioned where the fence changes direction. A fence may change its angle because it is the corner of the paddock or it may be to keep the fence line on particular terrain or away from difficult to fence areas

Angle posts also need to have stays and foots in place to work well.

Once again, in an angle the forces of straining the wires are in place. The wires are pulling in the direction of  to try and pull the post in this direction 

To counter this force there has to be something pushing the opposite direction from the 

This is where the stay comes into play. The stay will push against the  post to keep it standing straight.

The stays and foots are constructed as they are for the strainer posts

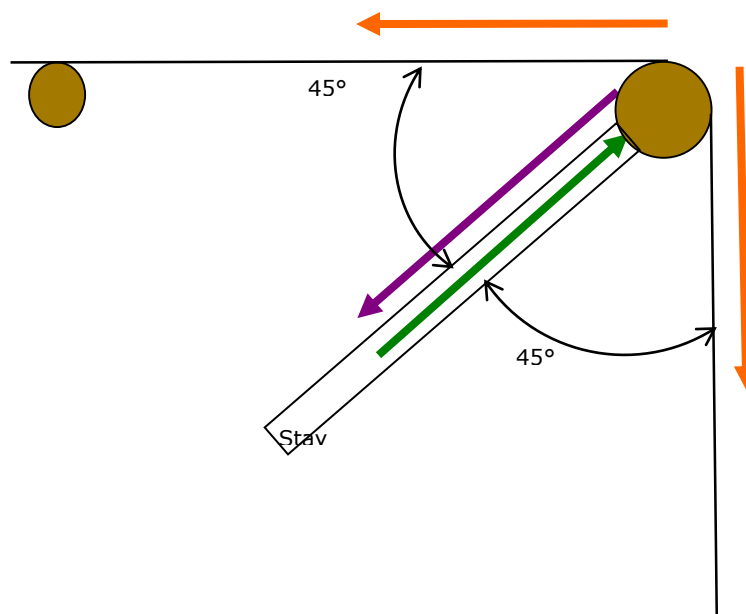

Line posts or intermediate posts

These are all the posts between either angles or strainers. If a line post is situated in a dip or on a high spot (rise) they are treated differently.

A dip post must be footed so that the wires do not pull it out of the ground. Rise posts have the potential to be pulled into the ground by the wires when they are strained.

Line posts are often thumped into the ground – the process being quite quick. If you do not have a post thumper or borer they must be dug in. Dig a small a hole as possible The posts must be well rammed. Dip posts must be footed. Ensure that they are at the right height

Wire tying

At some stage in your fence line you will have to tie wire.

This happens at the end of the fence line, where they are strained up or where a coil runs out and you have to start another.

The two types of wire work are

- **joining** (usually along the fence line) and
- **termination** (at the end of the fenceline)



Joining

Where two wires join together, a strong durable knot is needed to ensure that they don't come apart

There are a variety of knots which can be tied to join wire. Under laboratory tests the following results came to light for 2.5 HT wire.

Reef knot 440kgf*

Figure 8 knot 470 kgf

Crimp Sleeve 620kgf

Double loop 290kgf

(*kgf refers to kilograms of force)

As a result of these tests it is now recommended that a Double loop knot should not be used.

It is sometimes still used when joining barbed wire to **4mm mild wire**. With regard to barbed wire, which is harder to handle and tie, it will often not go right to the end of the fence line to be tied off in a termination knot. Instead is attached to a short piece of plain wire. It is however possible to tie a termination knot with practice, and this does look neater. Also there are now



Reef knot



Figure 8 knot



HC2 crimp sleeve

crimps available for joining barbed wire.

Figure 8 knot

This is a commonly used joining knot. After the wires are strained to the correct tension using fencing strainers the surplus wire ends of the knot are wrapped closely along the line wire and broken off close to it. This gives a smooth finish and when done correctly you should be able to run your hand either way along the line wire.

Step 1	Step 2	Step 3
Put a loop in Wire A	Thread wire B through the loop on Wire A	Position B under A and then bend back over A and under itself

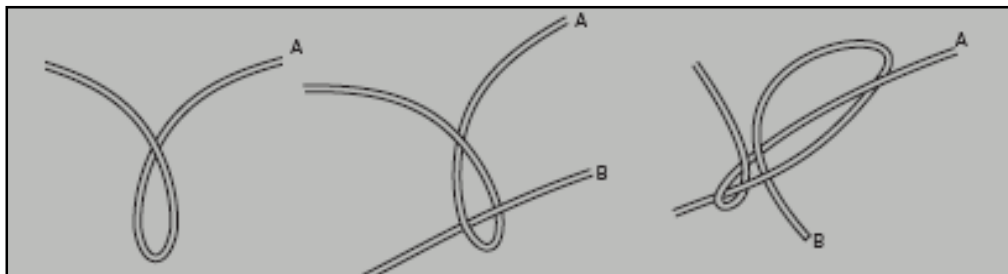

Step 4	Step 5
Tighten the loop in B	Pull the knot together

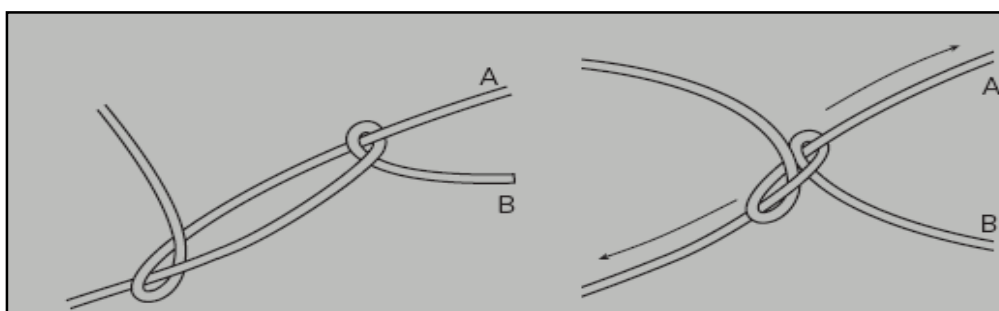

Once it is tight, wrap the ends to give it a

neat and tidy finish. This knot can be used to join two wires anywhere in the fence line



Termination knot

This is the knot used at the end of the fence line to attach the wire to the strainer. If a termination knot is required the wire is wrapped around the post (or through a concrete strainer) before being tied off and tightened.

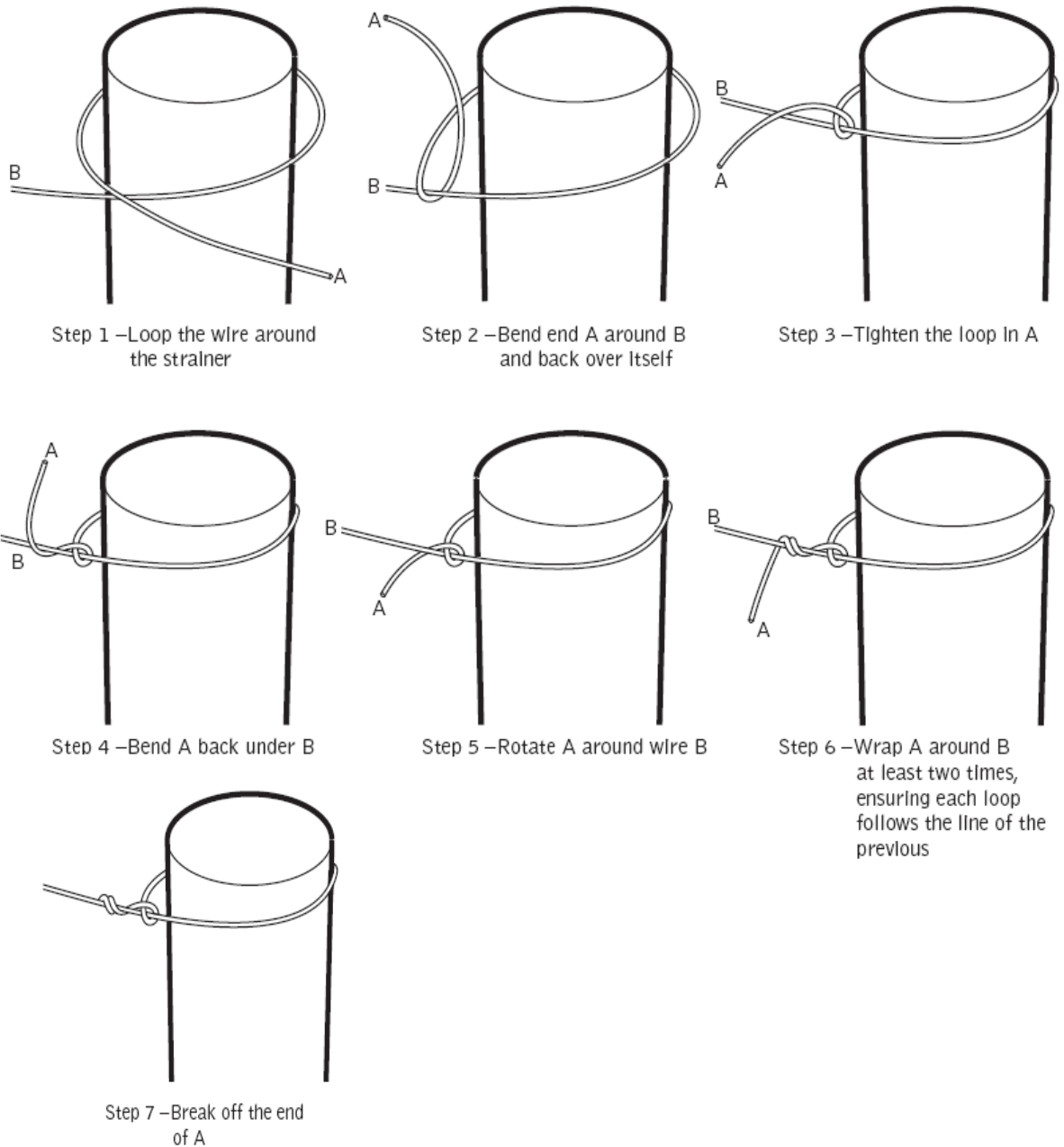

Step 1 – Bring the short end around the post and under the long wire



Step 2 – Bring the short end back over the wire then under on the other side



Step 3 - When the knot is tight slip it up towards the post



Step 4 – Bring the short tail under the wire



Step 5 - Then bring it back



Step 6 – Bring the short end over the long wire so that it forms a lazy loop. Note that the other end of the short wire now has a bent handle to use



when finishing the knot.



Step 7 – Continue wrapping the wire around keeping the loops tight around the wire and close together



Step 8– Complete three loops around the wire



Step 9 - Bring the wire back past the three rotations making sure the crank handle is still in place



Step 10 – Rotate the wire towards you and around parallel to the wire



The completed termination knot



The completed lazy loop should be about two fingers wide.



Note that the wire does not come from the centre of the post but on one side (approximately 1/5 from the edge)



Tex Brown knot

The Tex Brown is used for tying off wire under tension, as it keeps the tension when the chain strainers are removed. It is the strongest of the knots used on the fence line at around 80% of the wire's strength

Steps

- Start as for a figure 8 knot
- Tie bends down and under, up and over, and around line wire.
- Finishing loops start one end over line wire and the other end under.
- Remove chain strainers.
- 3 tidy, tight loops and a clean break to finish.

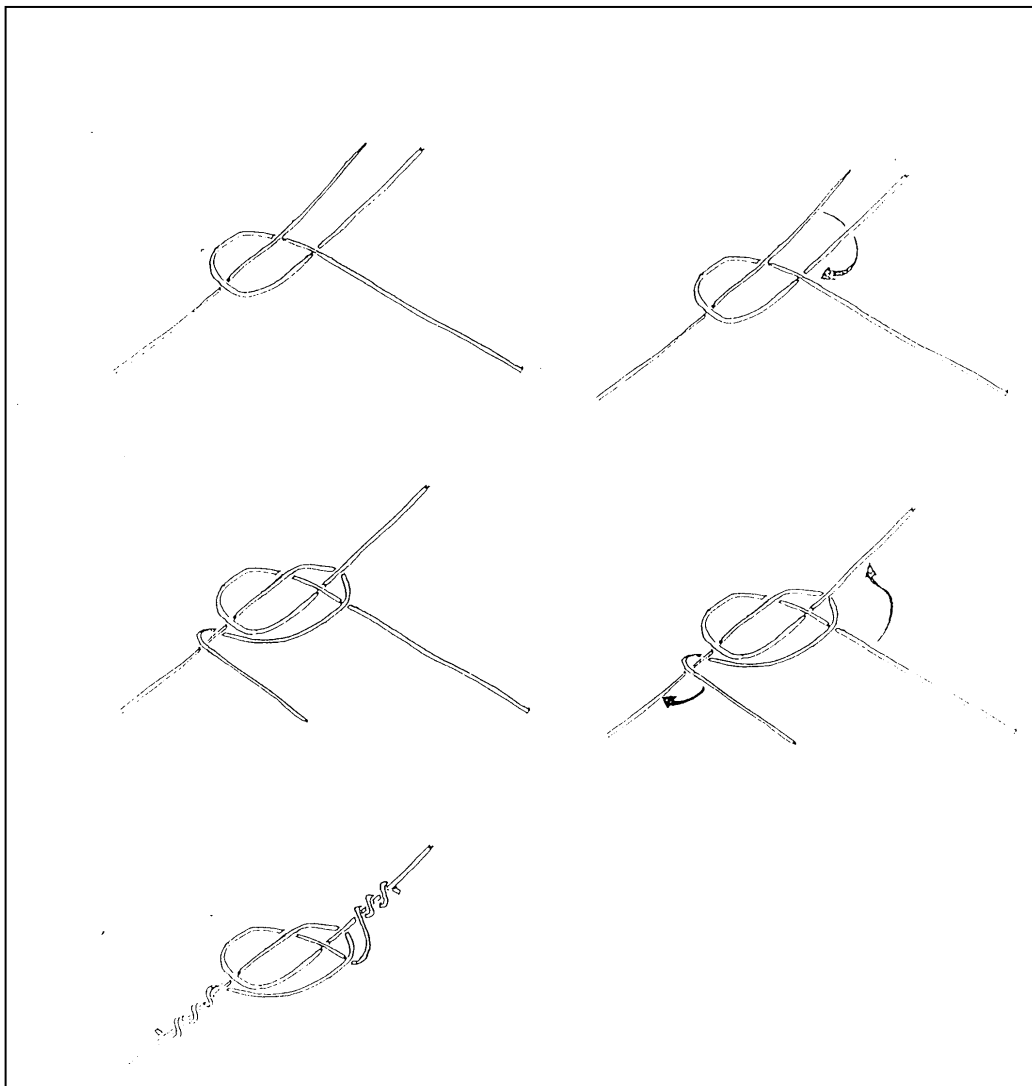

Breaking off the wire

Once the wire is tied and the knots are complete loose ends are dealt with. For mild steel the easiest method is to cut the wire with wire cutters or pliers. Normally if the excess is cut with pliers, it leaves a jagged end which can be dangerous so take particular care to be sure not to leave any long snags of wire that can potentially harm stock.

It is possible to snap high tensile wire fairly easily by applying a 'reversed torsional twist', which gives a neat tidy break which is not jagged. Great strength is not required for this, (but demonstrations are impressive). Ensure that the break occurs on the underside of the wire. This method will work easily with high tensile wire, but requires a little more effort and care with mild steel

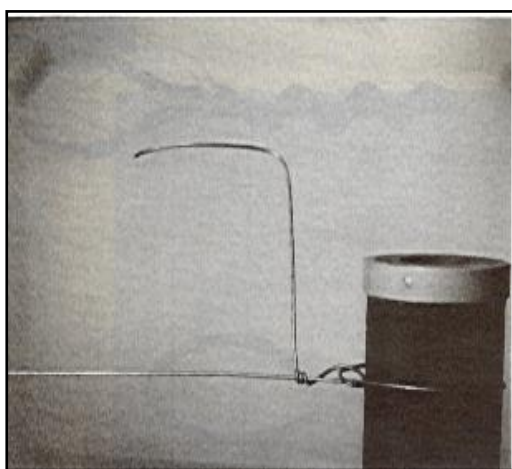

A 'handle' is formed parallel to the line wire to manipulate the wire easily

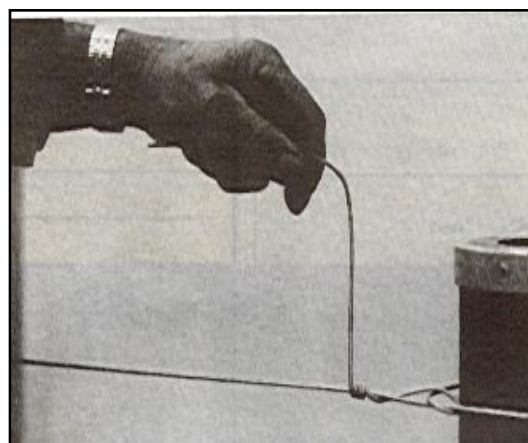

The wire is wound around the line wire two or three times

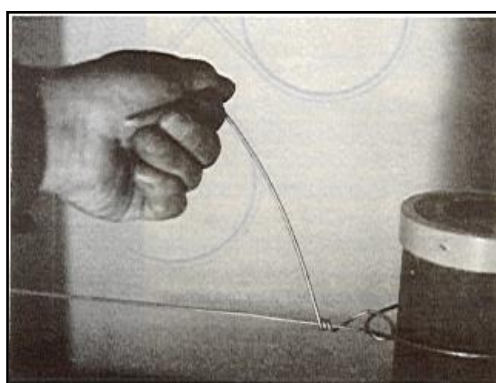

The 'handle' is twisted so that it is perpendicular to the line wire

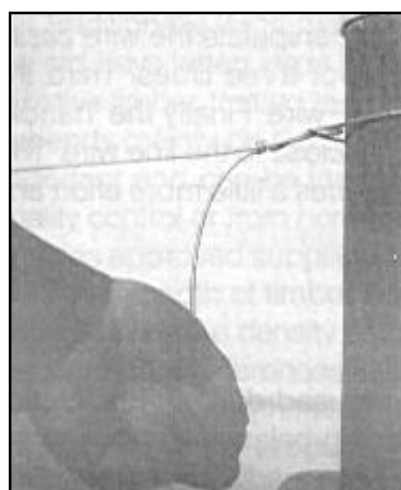

The 'handle' is turned as shown, causing the wire to break cleanly close to the line wire

Attaching battens & droppers

To ensure that wire spacing remains consistent, and to improve stock retention, wooden battens should be stapled to the fence between any line posts.

The purpose of battens is to maintain wire spacing so that stock cannot push their heads through the fence. Even if posts are three metres apart, at least one batten is desirable.

Using a stretchy piece of elastic with 4, 5, or 6 marks on it (corresponds with the number of battens you want between each post) Stretch it between the posts and lay out the battens where the marks are. This should ensure even distance between battens on your fence line

Although there are compressed staple guns that can now be used to attach a batten to the fence most people still rely on a hammer

If using a hammer then this job is best done with two people. One holding the batten and the other hammering in the staples. If there is only one person doing the job they have support the batten with their body and reach over the wires to staple them on. This is more difficult for the bottom wires.

The placement of staples is very important

They should not be placed down the centre of the batten but on alternative sides. The staple should also be placed over the wire at an angle. This too alternates from side to side. By doing this is should lock the batten in place on the fence line.

The top wire is about 50mm from the top of the batten.

Staples should be hit in far enough to indent the wood with the wire.

Try not to put staples too close to the outside or they may splinter the wood.

A second staple can be placed the opposite direction to the first on the second wire. This increases the locking ability of the staples to keep the batten in place on the fence line.

By doing these three things, the battens should stay in their place.



Wire droppers

Their manufacturer's claim these are quick and easy to install. They are light to carry to the fence line and are strong enough to hold up to heavy impact. They can be positioned and locked into place in just seconds with a flick of the wrist and a screw driver.

They are made from 4mm heavy galvanised high tensile spring steel. They are also low maintenance and last a long time making them a viable alternative to the traditional batten

Installation

Step 1 Hold dropper against the fence with loops parallel to the fence and engage wires with a downward movement.

Step 2 Rotate the dropper anti clockwise to lock wires in the loops.

Step 3 Position tails onto top and bottom wires with screw driver or pliers

To remove

Reverse steps 1-3

Size Range Available:

Length	Spacings Wire (mm)	Fence Wire Suitability
711	178 - 152 - 127 - 127 - 127	6
914	203 - 178 - 152 - 127 - 127 - 127	7
940	225 - 178 - 152 - 127 - 127 - 127	7
965	203 - 152 - 140 - 127 - 114.3 - 114.3 - 114.3	8

Gates

Gates come in many different shape, sizes and designs.

Timber gates

Timber gates are still an option today but they have largely been replaced by steel gate.

Timber gates are heavier and cost more to buy. If they are made out of inferior wood they do not last long. They may warp or break at weak points e.g. knots.



Being heavy they often take more than one person to hang. The weight of the gate will also put more pressure on the strainer it swings on. For a really heavy gate a larger strainer will be required.

Farmers may construct their own gates if they have available timber hereby making them a cheaper option than a metal gate. The easiest way to construct a wooden gate is to have a template to work on. The more sturdy gates are a double thickness however these are very heavy. (but strong)

Wooden gates are a more visible barrier for stock than metal gates.

They also look good and so are often used near the road frontage. E.g. Next to the main driveway.

Steel gates

Metal gates are light and cheaper than a timber gate.

They are galvanised to reduce corrosion.

Generally the lighter the gate the cheaper it is. The really light gates will not stand up to high stock pressure a more sturdy design is needed.

Being lighter they are easier to get out to the fence line and for one person to swing.

The main differences in design focus on:

- Metal bars thickness
- Distance between bars
- Direction of bars
- Type of bracing (if any)
- Use of netting

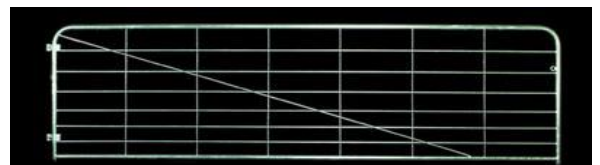
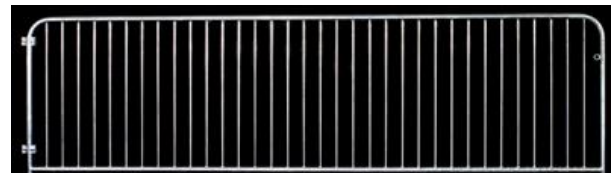
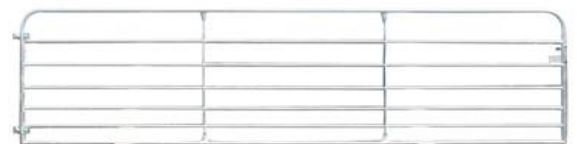
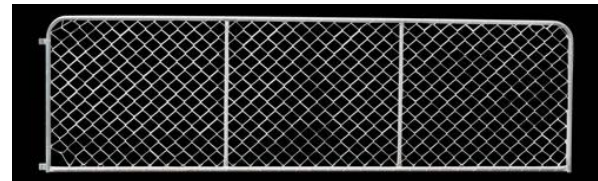

Hanging a gate

Gates are hung on strainers. The strainer should be dug in at right angles to the ground in the gateway. Using this as a rule it is possible to hang a gate on sloping ground as long as the post is at right angles to the ground. The best place for the hinges or clamps on the gate are close to the top and bottom (as far apart as possible).

The first step in putting up your gate is to stand the gate in the gateway with the top of the gate level with the top of the strainer. You can prop the gate up on blocks of wood.

With the gate hinges close to the strainer you can work out where to put in the gudgeons. The first mark you make on the strainer is just under the eyes of the hinges. This is where you are going to put your gudgeons.

The gate must be plumb when you do this or it will rise and fall when it opens.

The next job is to put the gudgeon into the post. It should be in such a place that allows the gate to swing right back along the fence line. For this to happen easily the angle the gudgeon is put into the post is 45 degrees. (see below) from the line of the fence.

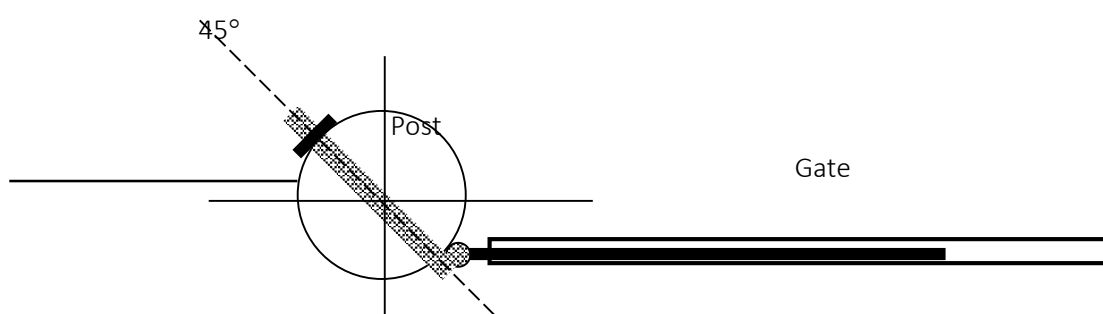

A heavy duty drill or brace and bit with the right sized drill bit is used to drill the holes.

Make sure you are drilling level through the post. Depending on the Gudgeons you are using you may have to screw them in or hit them in. If you are using screw in gudgeon your drill bit is quite a lot smaller than the gudgeon. If you are using through post gudgeons the drill is the same size or a fraction smaller than the gudgeon. You may also have to drill a second hole if you are using Gudgeons which lock in place. Gudgeons should sit approximately 7cm out from the post. When shut the distance between the gate and post should be as even along the length of the post. Also the top of the gate and the post should be at the same level. To get the gate swinging well adjustments can be made to the Gudgeons by turning them in further or out further.



The last step is to attach the latch. Attach the latch to the gate first and then the staple to the post so that the latch is easy to use but does not hang too loosely. If one side of the fence is not used by stock. (E.g. the roadside) the staple should be put here.

Gudgeons

There are many different types of gudgeons for different posts and situations



Product ID	Dimension a (mm)	Dimension b (mm)	Dimension c (mm)
Y2051	100	12	41
Y2052	105	16	31
Y2053	140	16	41
Y2054	150	20	51
Y2055	150	20	65
Y2057	200	20	65



Screw gudgeon

Used where the strength and security of the through post design is not required

- Tapered thread tightens as gudgeon is screwed into the post
- Long pin prevents gate lifting off
- One piece gudgeon end reduces the possibility of corrosion.

Through-post gudgeon

These gudgeons can also be used on wooden posts. They are hit through a post that you have drilled ensuring that all washers and nuts are used in the right place. You can see in the picture that some gudgeons have nuts and washers on both side of the post while others just have them on the end of the gudgeon.

Hang any type of gate where the strength of the through post design is required

- Long pin options will allow for gate security when required
- Back nuts allow gate adjustment.

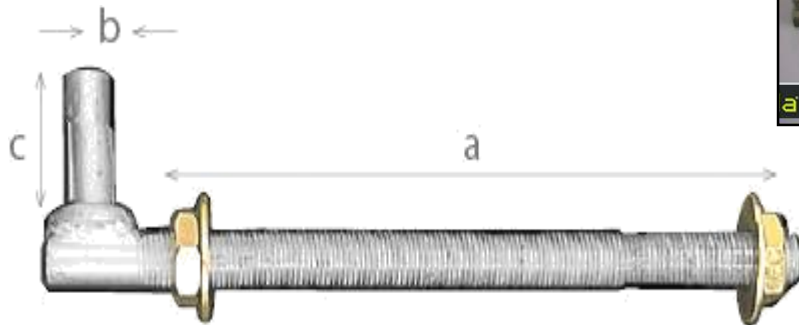

Product ID	Dimension a (mm)	Dimension b (mm)	Dimension c (mm)
Y2011	190	12	41
Y2013	250	16	41
Y2014	275	20	51
Y2015	275	20	65
Y2017	350	20	65
Y2018	425	20	51
Y2019	425	20	65

It is possible to use a combination of gudgeons- e.g. a lock-through post gudgeon on the top with a screw gudgeon on the bottom.

Large stock have been known to lift gates off their hinges so some gudgeons have a hole in the top of the pin to insert a locking device.

Farmers also just hit a nail over the top of the gudgeon so that the gate cannot be lifted. Either option works.

Lock-through gudgeon



These gudgeons have a locking mechanism. When they are hit through the post there must be a second hole drilled so that the bar under the post can also be hit into the post. This secures the gudgeon very securely. To get the second hole in the right place hit the gudgeon through the post until the locking bar makes a dent in the post.

Turn the gudgeon slightly to reveal the mark and drill here. Turn the gudgeon back, line everything up and finish hitting home. Make sure all nuts and washers are in the right place before starting.

Often used as the top gudgeon when hanging gates for the additional strength provided by the locking shaft which resists any lateral force that may be applied to a gate

- Can also be installed upside down to prevent gates being lifted from their hinges
- Recommended for most farm gate installations
- Long pin prevents gate lifting off.

Product ID	Dimension a (mm)	Dimension b (mm)	Dimension c (mm)
Y2001	200	16	41
Y2002	250	16	41
Y2003	275	20	51
Y2004	350	20	51
Y2005	425	20	51
Y2006	275	20	65

Concrete-post gudgeon

Concrete strainer posts are still in use so you can purchase these gudgeons which strap around the post.

- One size designed to fit all common sizes of concrete strainer posts from 125mm to 200mm square
- Two-way model available for situations where the gate opens back against the fence.

Product ID	Dimension a (mm)	Dimension b (mm)	Dimension c (mm)
Y2061	125/200	20	51
Y2062	125/200	20	51

Latches

These are two popular latch types. They are attached to the gate either by staples if it's a wooden gate or by opening up the loop on a metal gate, slipping the chain into the loop and closing it up again.



The large staple is hit into the post to secure the latch to the post.

This latch is less common these days. The two flaps hold it in place so that stock cannot lift it easily through the latch staple.



This is a popular type of latch today. They both come with a ring to move before it is lifted through the latch staple however in the bottom latch the ring is spring loaded so that it is harder to use. This is a precaution to ensure stock do not undo the latch. Cows can become quite efficient at licking latches through the staples.

The chain is attached to the gate at the right length through a special open ring which is later closed.



Rails

Rails are usually used around gateways. Rails are stronger so often found in areas where there is a lot of pressure such as gateways and yards. They are often used where a short fence is needed such as at the end of a shelter belt. Rails are also easier to construct where there are fiddly fencing jobs. Where there are lots of different angles where using post and wire would be a lot more difficult. Lastly rails are often used around buildings and entrances because they look nice.

The important criteria for a railing fence is

- Stock Retention – it must keep stock either in or out.
- Durability - it needs to last despite the wear and tear of stock, weather and natural aging.

The design depends on the animal it has to contain. It is also affected by budget and personal preference

Common sizes

The most common sizes of railing timber are:

- 125 x 32 (5x1¼)
- 150 x 32 (6x1¼)
- 150 x 50 (6x2)

The timber is rough sawn and does not have to be ground treated. H3 will do. There is a profiled railing available but this is used mainly for more decorative jobs.

Flood Gates

Erecting flood gates

Flood gates are usually situated in low areas (gullies or creeks) which the fence traverses. These low areas periodically have water permanently or sometimes only when there is a heavy rainfall.

Whichever the case the flood gate is designed to stop stock moving through the water and under the fence no matter what the level of water is. Therefore the flood gate has to adapt to the changing environment by lifting when the water level is high and dropping back down as the water level drops.

The flood gate should not be attached to the fence as on occasion during a lot of pressure the flood gate may be lost. An independent flood gate will not take the rest of the fence with it.

To reduce the likelihood of losing a flood gate it is best if it is designed in such a way that it will not easily pick up the debris that is washed down in the water.

Because the flood gate is often a temporary piece of fencing the farmer often constructs it out of the material that he has lying about and adapts the design to the material.

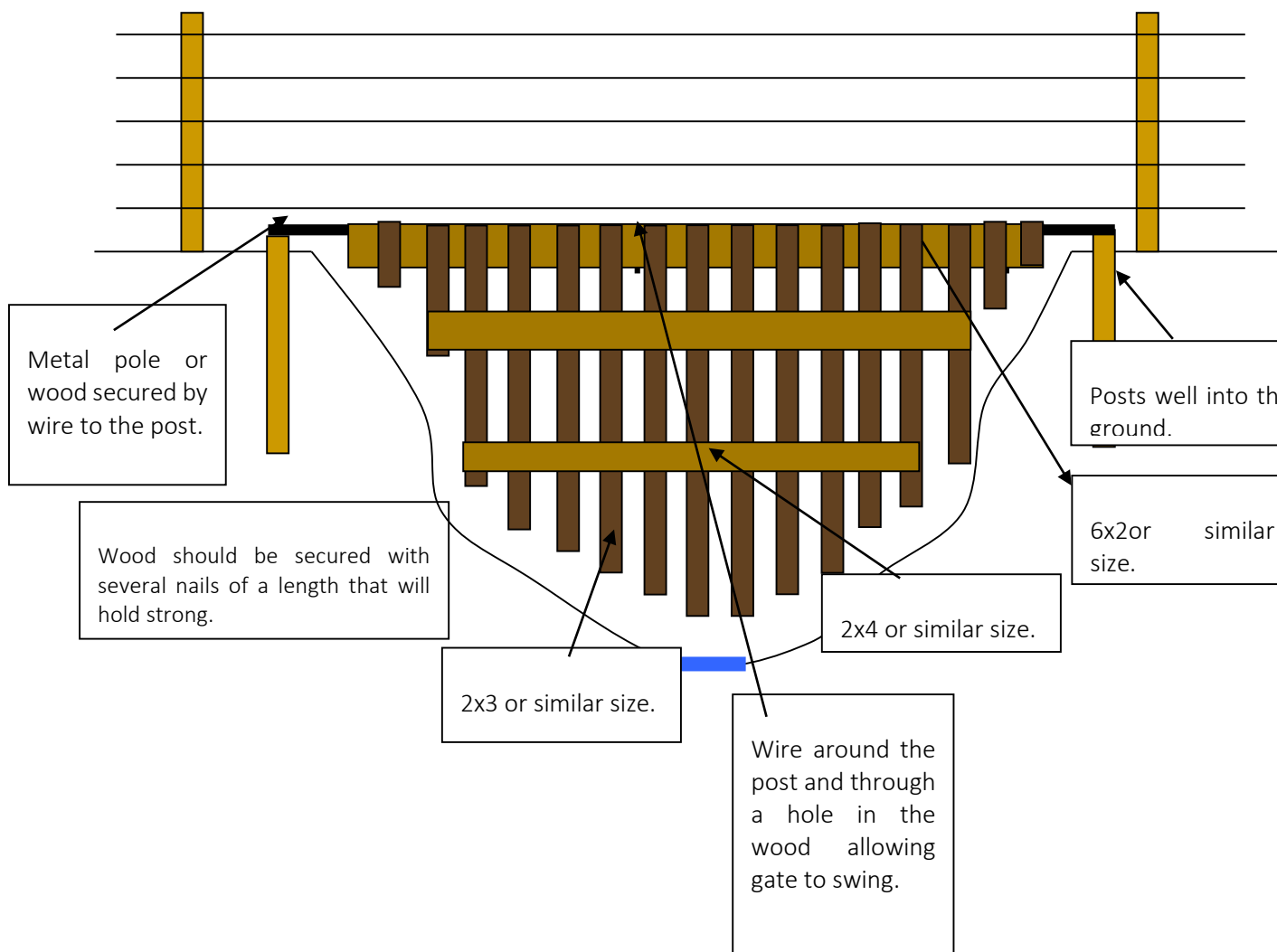

- There should be no gaps between the timber, the timber and the ground, or the gate and the fence, which are big enough for stock to squeeze through.
- The gate should swing freely and the gaps should allow some debris to pass through.

Another popular design is one using corrugated iron instead of the timber. This keeps the construction quite light, and the tin floats well on rising water. Being a relatively flat surface with not holes it does not collect debris. It can occasionally be affected by the wind but the noise of this moving construction usually deters stock from sneaking through.



Often the design is dictated by the terrain. Sometimes the fencer has to be quite inventive to navigate problems. Whatever the final outcome there remain these five important features that the construction must have.

- It must meet the contour of the land so that stock cannot sneak through.
- It must move to suit rising water levels.
- It must not collect debris.
- It should work independently to the fence.
- It must return to place after the water level has receded.

These are just two designs. The first is by far the more attractive and looks good on a fence. Farmers though are an inventive and resourceful lot which is why other materials such as corrugated iron, concrete reinforcing, old gates or whatever is lying out the back that will do the job have been used.

Here are some examples of large flood gates



Section 5

Building the fence

Planning what to build

Before making the final decision as to what type of fence is to be used, consider the following:

capital costs

labour cost

maintenance costs

stockholding ability (present and proposed stock should be considered, also consider the type of stock neighbours have when constructing a boundary fence)

required service life of the fence – there is no use buying materials that are unlikely to give the life span that you require

flood or fire risk – no use having a battened fence in a flood prone area

risks of soil slips or movements

climate risk (e.g. severe corrosion by the coast)

availability and skill of labour

availability of materials

After all this consideration you should have a design in mind that will achieve the animal containment job it is required to do. It will suit the terrain, your farming system, and your budget, and it will last.

Planning where to build

When deciding on placement of fenceline consider the following

Boundaries: Check the accurate location of boundaries before erecting the fence. Discuss plans with your neighbour.

Class of land: Where possible fences can be used to separate one class of land from another, whether it be due to different soil types, or aspect (sunny, shady etc.).

Ease of access: A fence line that can be bulldozed will reduce transport and erection costs, but may lead to erosion problems.

Avoid problem areas. These can lead to extra materials and maintenance, e.g. soft soils are troublesome for fence end assemblies, corners, or angle; rock - can make post installing very difficult; unstable streams may meander, and cut off, or undermine fences.

- **Slopes prone to slipping-** fencing straight up and down a slope will suffer less from snow and boulders. If a slope must be crossed look for old terraces, or changes of slope, which may break the slide of snow.
- **Gullies which are susceptible to floods** - these will require a portion of fence to be collapsible (floodgates).
- **Avoid unnecessary dips or bends.** Nearly every dip will require a tie-down or foot. Likewise bends will require bigger posts or strainer assemblies. (Angles).
- **Make the strain as long as reasonably possible.** Good flat going may allow 1200 m strains but in rough ground you may be down to 100 m.
- **Careful siting of gateways** – can make stock movement a lot easier.

The lay and the shape of the land will influence your decision. You may decide on some human intervention and push in a nice even flat line with a bulldozer on which to construct your fence.

It's a good idea to limit the number of angles in your fence if possible. This may include taking into account the number of rise and dip posts as well.

- Will you go round a spur or over it?
- Will you run across the ditch or alongside it?
- Will you fence off the boggy patch or straight through it?
- Will you go down the spur or the gully?

Selecting material

Post Sizes

Length, SED and shape (round, half round or quarter round).

Length (how far will it go in the ground)

Experiments with Radiata pine posts have shown that there is a relationship between post diameter and the necessary depth for the post to be buried in the ground to stop it overturning.

In medium clays a post which is set in the soil to a depth ten times its diameter (or more) will usually fail by breaking.

In softer soils the 1:10 ratio becomes as large as 1:15, so a 90mm post set 900mm in soft soil will fail by over-turning. In other words, to obtain a stronger fence there is little to be gained by using a larger diameter post, unless it is balanced by using a post which is longer too.

The Relationship between depth of post in the ground and strength

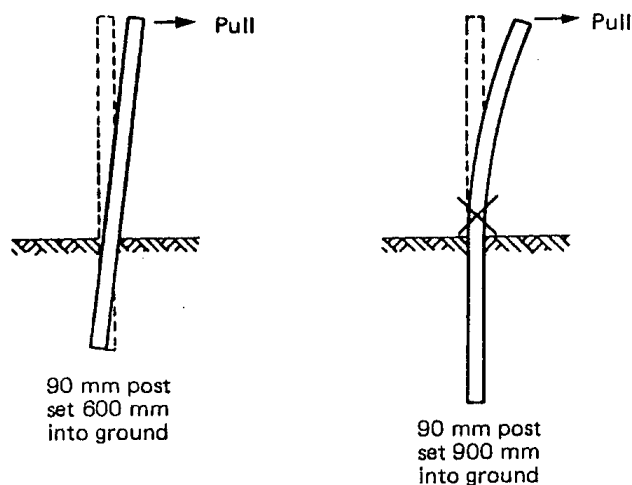

The only benefit of the larger diameter is the increased face width pushing against the soil. It can be seen that the extra strength of the No.1 post (for example) is wasted with a 1.8m post. Because of its extra width a No.1 half round post of the same length in the same ground would be stronger.

Unfortunately longer posts are disproportionately more expensive so the standard 1.8m long post is almost invariably used.

The first thing on the job... is the end

After you have taken your tools and material to the job site your first job is to put in the ends of the fence line – the strainer posts. It's a lot like a foundation of a building – getting this right is important because it will affect the rest of the job if you get it wrong.

Digging a hole

Tools required:

- Spade and shovel
- Hammer
- Spirit level or Plumb bob
- Rammer

1. Site the post
2. Remove the turf:
 - at appropriate contour change or at sites dictated by the number of posts per 20 metres
 - place turf clear of where the earth will be placed
 - dig to necessary depth and size
 - hole to fit size of post but not be over large
 - place earth in a compact heap alongside turf

- the face of the hole must be vertical to the contour and directly beneath the guidewires.
3. Place posts in hole:
 - ensure **correct height** (use a marked rammer for guide).
 - keep in height with the rest of fence.
 - correct contour.
 - with round posts, the straightest portion should be above the ground.
 - post to be standing vertical to contour but 2 mm away from guidewire.
 - post **should not touch wire**.
 4. Add earth:
 - about 10 cm of the earth that has been removed is now rammed firmly round the bottom of the post.
 - keep adding earth and ramming until the earth is replaced and finish with the turf grass-side up and well rammed.
 5. Staple to post:
 - spacing is taken off existing post and marked
 - wires are stapled at correct spacing
 - staples are left 5 mm from being driven home to allow wire to move freely.
 6. Surplus material is removed
 - site is left clean and tidy.

Dig the holes, put in the end assembly (choose the type that suits the soil and terrain). It is a good idea to mark the wire spacing on the strainer post. An old broom handle or similar type of wood with the wire spacing marked on it is a good template to have so that you can lean it against the post and accurately mark with your pencil where the wires are going to go. DO NOT get your stick the wrong way up!!

Put in your strainer

Select the end assembly that will best suit your fence and terrain. Dig the posts in, foot and stay them using a system that suits the soil and terrain

Put in the angle posts.

Hopefully you have chosen a line that will not require too many angles. Dig the posts in, foot and stay them using a system that suits the soil and terrain

Run your guide wires

Once the strainers and angle posts have been installed, the fence is ready for the guide wires to be run out and installed.

Running out the wires

The spinning jenny will normally be positioned near the strainer at the higher end of the fence - it is easier to pull wire downhill than uphill. The jenny should be on level ground, preferably behind the strainer and slightly offset from the face line of the fence.

The face (wire) side of the fence:

- will usually **be the uphill side**, so that stock pressure forces the wire against the posts and not just the staples are relied on to hold wires in position.
- the exception to this would be where frequent heavy snowfalls are expected. If the snow forces the wires downhill and pulls staples at least the posts are still intact.
- on flat ground the wires should be on the **fence side from which the greatest stock pressure is expected**.
- on ridges the prevailing wind direction may be the determining factor.
- Where the fence looks good. E.g. on the driveway.



Loading the coil

Load the coil of wire onto the spinning jenny. The tag end of the wire should be on the top (remember, for a part coil you should have a bent end instead of the tag. This will leave the jenny to **spin in an anticlockwise direction**.)

Remove the light lacing wire from the coil, place it carefully somewhere handy (under the jenny). Most will be scrap, but some may be needed to retie the remainder of the final coil. Most farmers, and smaller contractors, will use a jenny that can take 1 coil of wire only. Some contractors use multiple jennies, capable of up to 9 wires. Wires can be pulled by hand, by motorcycle, by ATV (four wheeler), or even by tractor.

Drawing the wire out

Carefully draw the end of the wire from the coil, moving slowly from the jenny in the direction of the fence, along the wire side. If the wire is pulling freely move steadily along the line toward the next angle or strainer. Do not try to move too quickly. e.g. run; a smart walking pace will do. Keep your speed even, and with it the speed at which the jenny turns. Sudden stops and starts may allow the jenny to over-run, shedding loops of wire which will then catch up, or even tangle. If you need to stop, dig the end of the wire in the ground to stop it spinning/recoiling back.

It will be necessary to tack the wire to any angle posts, and install another staple behind the wire.

This holds the wire off the face of the post and allows it to slide more readily.

This can be done after the wire has been run out.

For repair work, and for some very short fence-lines, it may be just as easy to feed the wire directly from the coil **without using a spinning jenny**. This can be achieved in two ways, depending on the circumstances:

Solo

Lay the coil on the ground with the outer (label) end uppermost. Undo the tie wires and locate the outer end. Fix this end temporarily near the strainer post. Pick up the coil, and move it away so that loops of wire pull from the coil one-by-one. It is vital that the direction of the coils be alternated, as this prevents looping, recoiling and possibly kinking of the wire.

One way to achieve this is to feed (say) 10 loops off the right shoulder and 10 loops off the left. Another (less efficient) way is to back along the fence holding the coil in front and feeding (say) 10 loops clockwise then flipping the coil sideways to feed 10 anticlockwise.

Two-person

As above, but rather than walking the coil one person draws out the end as with a jenny, while the other person feeds loops alternatively from the coil while remaining near the strainer.

Run out and set line wires

The **first wire pulled** will depend on the country being fenced on...

- On **hill country**- 1st wire is **bottom wire**, 2nd wire is **second from top**, then work from the bottom up.
- On **flat country**- 1st wire is **second to bottom**, and 2nd wire is **top**, then work from 2nd bottom up.

(If the top wire is barbed, use the 2nd from top wire as the 2nd wire run out).

Having reached the far end strainer use a **termination knot** to tie the wire to the strainer. Be sure that you run the wire on to the correct side of the strainer. Use light staples tacked into your post where the wire spacings are marked to get your wire in the right place and running level around the post.

The correct side of the strainer to wrap the wire around is almost always the **face side of the fence**.

Termination Knot, or Post Tie-off Knot

Tack a couple of staples into the strainer where the guide marks for the wires are. When you have run your first wire out and reached the strainer you can thread the wire around the strainer through the staples hereby guaranteeing the wire will be in the right place and level. When the fence is strained up, take out the staples.

Face side of fence

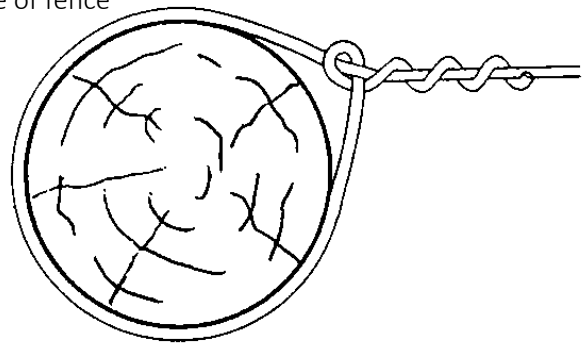

Tie off the wire using a termination knot.

With a vertical strainer assembly the wire should run down the face side of the stay, as close as possible without touching it. This will mean the wire is slightly off-centre.

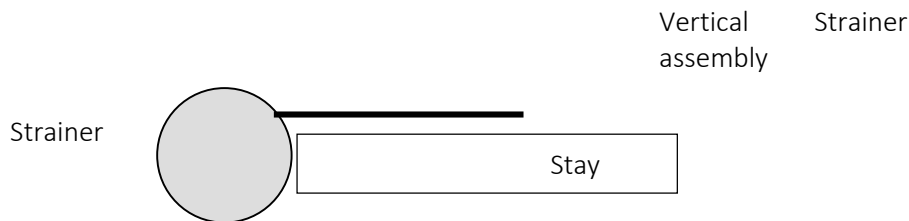

With a strainer assembly that is breast-plated, the wire should be centred.

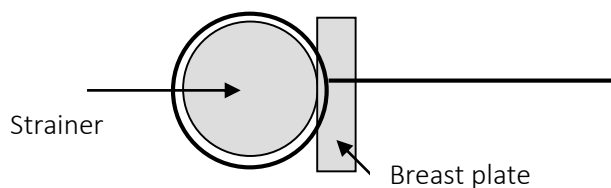

On the way back along the fence count the number of dips which need "feet" so that these can be prepared, ready for distribution while pulling out the second guide wire.

The first wire can be stapled to any angle posts. Make sure a sliding staple is used on angles, to give a sliding surface for wire, when tensioned.

On reaching the start strainer, pull most slack wire from the fence-line, allowing enough length beyond the strainer for wrapping, tying off, and straining.

Then cut the wire, dig the jenny end into the ground, and tie the end of the fence wire off at the strainer, at the correct gauge. Keep the wire on the same side of the strainer, as with the start strainer.

Second wire

Pull out the second “guide” wire, and tie it off at the end strainer. Staple angle posts at the correct height and tie the wire off at the start strainer.

These two wires are now ready to be strained to show straight lines from strainer to angle, angle to angle, angle to strainer.

Tensioning the wire

A “**chain wire strainer**” is one way used to pull up tension.

When first learning to use this tool the operator can feel quite clumsy but with some practice they become easy to use. Their simple design makes them extremely efficient at their job and no fencer can work without them.

The chain strainer’s job is to tension the wires and create a space where wires can be tied together so that when the strainer is removed you are left with the wires tied with a strong knot/joiner that maintains the tension in the fence.



Chain strainers work in the following way.

- On the **face side** of the fence, 2 - 4 metres from the strainer post, take the chain-end clamp of the wire strainer in your right hand and position it on the wire.
- Run the chain through your hand, retaining sufficient tension to hold the clamp firmly on the wire.
- Near the end of the chain, attach a hook of the strainer handle to the chain.

Shift the right hand so it is firmly gripping the handle end, pulling the chain and short wire up firm.

- With the left hand reach as far as possible along the fence wire and pull it towards the wire strainer. If necessary re-grip it under the right thumb, and reach back for more slack wire.
- When the wire is pulled up as firmly as possible, attach the handle-end clamp to it, and move directly backwards to tighten the wires, and the clamps' grips on them.
- Walk the two claws up the chain by using the handle. This will pull the two wires closer together hereby tensioning the fence wire. To begin with strain a little tension (50-60 kg force) onto each wire.



Then, at each end of the fence you must check that:

1. The wires are set at the correct heights.
2. The wires are running level and evenly around the strainers.
3. Wires are set approximately a fifth strainer width from the face.
4. The wires are plumb i.e. vertically above/below each other. Use a spirit level or a rammer.



If everything is where it should be, continue to strain up the wires. When the wires are at the right tension it is time to tie the two wires together using a figure 8 knot, tex brown knot or a crimp sleeve joiner.



Reverse the process to take off the strainers

Permanent in line strainers can be used on shorter lines. These are tied on to the wires and wound up to increase the tension. A special tool/handle is required for this. Over the years there have been several designs of these types of strainers but by far the most popular are these



A ratchet handle winds up the spindle which has a locking pin to stop it unwinding. If the fence needs tightening at a later date it is easy to restrain by just winding up the strainer a little more.

These do not work well on long fence lines.



The line posts

With the guide wires nice and tight, it is easy to see where the rest of the posts go. You are able to get the hole positioned so that a flat side of the hole is up against the wire which is where the post will sit. Rise posts should be 25mm higher and dip posts should be placed 25mm lower to maintain bottom of wire height. This will ensure ground clearance if the rise post should sink or the dip post should lift. You will have to foot any dip or rise posts as you go.

Dip posts are under considerable amount of tension and so need to be firmly footed into the ground



The rest of the wires

Once all of the posts are in you can run the rest of the wires using the same method you did for the first two. There is the potential to get in a bit of a tangle so work from the bottom to the top being careful not to cross any wires.

Once all of the wires are tied off you can start to staple them to the posts. The posts should have had the wire gauge marked on the post. Be careful to attach the right wire to the right mark otherwise, you will get your wires crossed.

Rise and dip posts should be stapled first and the remaining stapled off after tensioning. Staple at 45 degrees to the line of the wire leaving space so you cannot quite fit a second wire through. This will allow the wire to feed through the staples when tensioning and prevent wind chatter.

On an angle post, a second staple should be put behind the wire so that the wire slides easily.

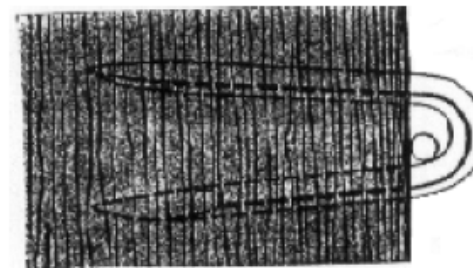

On long strains, especially if two or three angles are included, be sure to leave one or two-footed posts unstapled at the farthest end from where you wish to strain. This will ensure an even tension along the entire line.

Once all wires are tied off, stapling of the remaining posts can begin. Start this by walking the entire length of the fence and stapling only secondary foots and rises, as this will even the wire tension.

Staples should never be driven all the way in on posts. Enough room must be left so that the wire can move freely. This way the strain from wire contraction during cold weather or slack from expansion during hot weather and strain from stock running into or leaning on the fence will be distributed over the entire fence. Driving staples all the way in increases friction and will result in shorter wire life. It also makes it difficult to tension wire uniformly on long runs and results in fences less able to absorb heavy livestock pressure.

In sharp dips and rises, two staples are recommended for better holding (as shown in the diagram).

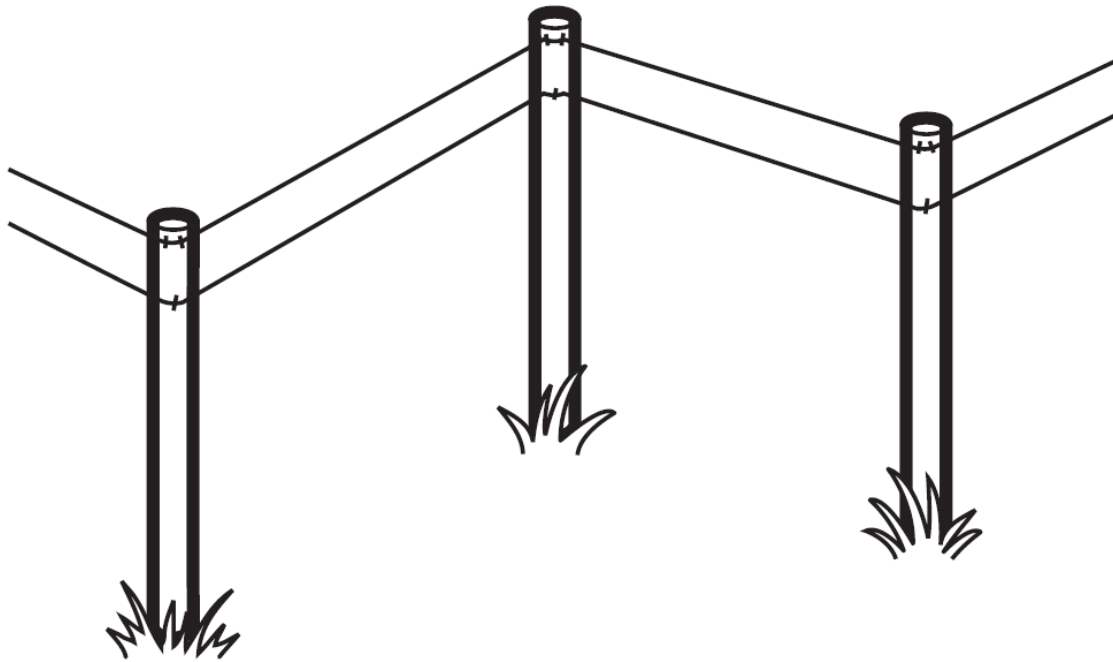

Several points should be noted when stapling wires to posts:

1. Staples should not be overdriven - the head of the staple should be just clear of the wire - say 1mm; 3mm is too far off. If the staple is touching the wire, it will restrict free slippage of the wire, both during tensioning and through the fence's life.
2. Where wires run level, so too should the staples be driven level. Where the wires fall from a post, the staples should be driven downward. Where the wires rise from a post, the staples should be driven upward.
3. On sharp foots and brows, double staple to lessen the angle of the strain
4. Avoid miss-hitting, as you may remove some of the zinc galvanising from the wire, considerably reducing its life.
5. Be tidy and efficient - remove all bent and twisted staples, and replace them.

Note- Pick up all staples you drop as they can cause problems in the feet of animals or if swallowed.

Battens

Attach battens evenly using the method described previously. They should be evenly spaced between posts at a distance of between 0.5 – 1.5m.



To ensure that wire spacing remains consistent, and to improve stock retention, wooden battens should be stapled to the fence between any line posts.

The purpose of battens is to maintain wire spacing so that stock cannot push their heads through the fence. Even if posts are three metres apart, at least one batten is desirable.

To ensure even batten spacing between posts, use a length of elastic with the number of battens being used marked upon it. When stretched between posts this will ensure even batten spacing.

Gates

Attach and swing gates using method described previously.

Flood Gates

Complete floodgates.

Rails

Finish off fence line by completing any rails that need doing. This may include a short fence, tricky angle, or where there is greater stock pressure such as beside the gate.



You can see that in this picture the fencer has 'arrised' the edges of the wood for a finished look.

Spacing

Like wire fences, a narrower space at the bottom with a wider space near the top is a popular design. This is not a hard and fast rule because you can have all your spacings the same. If you are fencing in horses, you need not have lower rails at all. You can also mix rails and wire together.

Height

The height of the fence is the first thing to decide. If it is attached to a conventional fence, it is likely to be the same height. If it is not attached to a conventional fence then the animal you are trying to keep in or out will dictate the height. Deer will require a much higher fence than sheep.

Timber

Once the height has been decided. The size of the timber is next to consider however, this is also dictated largely by your design.

Construction

Rails are attached to posts but these posts do not have to be stayed because there is no force at play trying to pull them over.



A railing should span between three or more posts. This is so you are able to stagger where the joints are. This enables you to not have all your joints on one post that would weaken your structure. Mark spacings on the posts before you start. This will save time in the end.

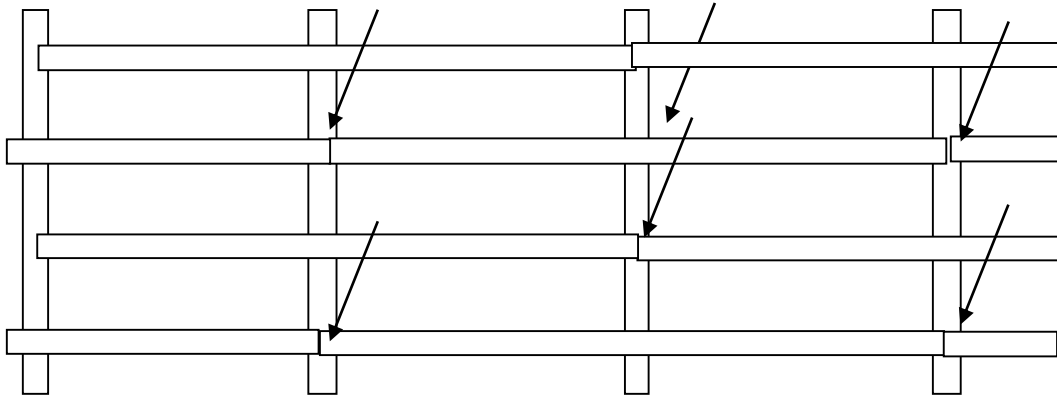

The nails you use should penetrate the wood as far as possible. Lightweight or small nails will not hold the rails if they are pushed from one side, or if the wood twists and warps.

For the more decorative look, (perhaps around the home) the railings can be butted into the post and nailed into position.





Cap rails are another way of adding a finishing touch

Today a lot of the timber available has been grown very quickly, and is not top quality if you are looking for a railing that is not going to twist, bend or warp after it has been exposed to the weather for a while. For this reason a good long nail must be used, and for extra protection, wiring is a good way of keeping the rail where it is meant to be.



At the top, the wire is bent over and attached. The end of the wire is hammered into the post.

When wiring on make sure the wire is as tight as possible over the rails. Staples can be used to tighten the wires if placed close to the railing

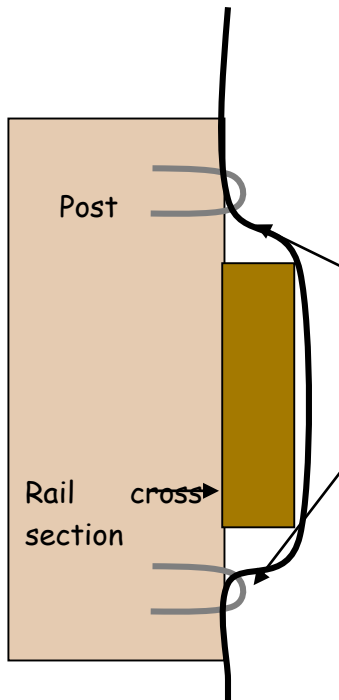

Staples here will hopefully pull the wire in really tight to secure the rail

Here are some different designs to suit different situations...



Replacing a post

Tools required:

- Spade and shovel
 - Hammer
 - Spirit level or Plumb bob
 - Rammer
1. Dig out the broken or ineffectual post
 2. Site the new post
 3. Dig the post hole to the necessary depth and size for the new post (if necessary)
 4. Place posts in hole:
 - ensure **correct height** (use a marked rammer for guide).
 - keep in height with the rest of fence.
 - correct contour.
 - with round posts the straightest portion should be above the ground.
 - post to be standing vertical to contour but 2 mm away from guidewire.
 - post **should not touch wire**.
 5. Add earth:
 - about 10 cm of the earth that has been removed is now rammed firmly round the bottom of the post.
 - keep adding earth and ramming until the earth is replaced and finish with the turf grass-side up and well rammed.
 6. Staple to post:
 - spacing is taken off existing post and marked
 - wires are stapled at correct spacing
 - staples are left 5 mm from being driven home to allow wire to move freely.
 7. Surplus material is removed
 - site is left clean and tidy.

Dismantling the fence

Tools required Shovel and spade

- Hammer
- Ezepull/pliers
- Staple Draw
- Crowbar
- Standard and post lifter
- Spade

Safety Gear

- Eye protection
- Leather gloves
- Appropriate footwear

1. Remove battens

- draw staples working from **bottom to top**, to stop the batten falling off before you have finished.
- collect **all** staples.
- leave battens in tidy piles for easy collection later.

2. Remove barbed wire

- remove and collect staples, cut wire at strainer, and give a 'flick', holding the wire end firmly. This will put the wire on the ground away from the fence.
- roll up in a coil of at least 1 m in diameter.
- remove plain wires
- remove and collect all staples
- remove one wire at a time
- cut wire at strainer assembly, starting from the bottom wire.
- roll up in coils as above, but try to have coils of 80cm diameter. With high tensile wire, try to roll in coil the same size as the original coil (high tensile wire has a good 'memory' for its shape).

3. Rolling netting

- Keep the roll as tight as possible. Push down lightly on roll as you roll.
- While rolling, regularly lift the roll and drag it backwards.
- Secure the ends of the netting to prevent unrolling later.

4. Dig out or lift posts
 - loosen soil to a spade's depth. Check for a wire foot.
 - cut foot wires if present.
 - remove posts. Use a post lifter, or tractor and snig-chain. Attach chains as low as possible on post.
 - foot may be left in the ground as long as there is no wire protruding.
 - fill in holes.
 - holes can be used to dispose of old staples and short bits of wire if the hole is deep enough that cultivation will not hit the metal.

5. Store or dispose of material
 - Away from animals and where it will not be buried in the grass.
 - Sort battens, posts, wire and staples into reusable, and rubbish.
 - Ensure **no** bits of metal or wire are left in the paddock for stock to eat.
 - Any rubbish wire should be buried deeply, so as not to be hit if the paddock is cultivated.

Adding Electricity

An option for farmers to make a fence more resistant to stock pressure is to add some electricity.

An outrigger attached to an old fence that may not be as stock proof as it used to be is a cheap way of getting a few more years out of a fence. This rejuvenation of the fence is used using offset brackets or outriggers as they are also known as. This can extend the life of the fence by quite some time.

This process can also be done to extend the life of a new fence. When constructing a new fence the fencer has the choice of outriggers or to just make a couple of the fence wires on the fence live.

To add offsets or outriggers to the fence

If the fence is in a bad state try to ensure that there are no slack wires or snags of wires that may short out the live outrigger wire. The wires on which the outriggers will sit will need to be well strained

Attach outrigger/standoff/offset. There are many models to choose from. Most attach to an existing wire or the posts.

Install the wire onto the outrigger

Live the wire using a mains system or solar powered system.

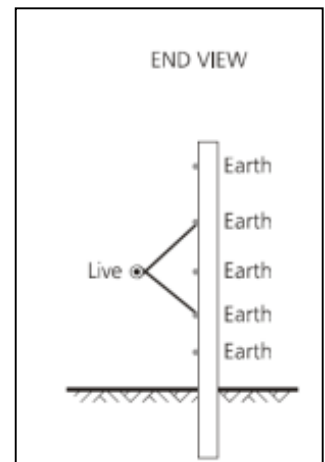
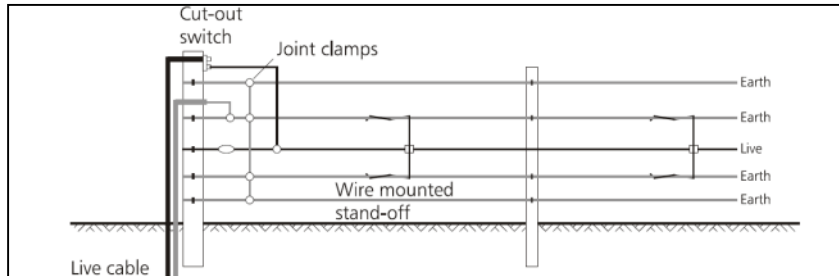

Sometimes it may be necessary to add an outrigger to both sides of the fence.

Types of offset brackets:

- Attached to the poles



- Attached to the wires



Instead of attaching an outrigger, one conventional wire may be substituted with an electric one. The points of contact for this wire must be insulated

Against wood on posts and battens



At the end of a line with an insulator

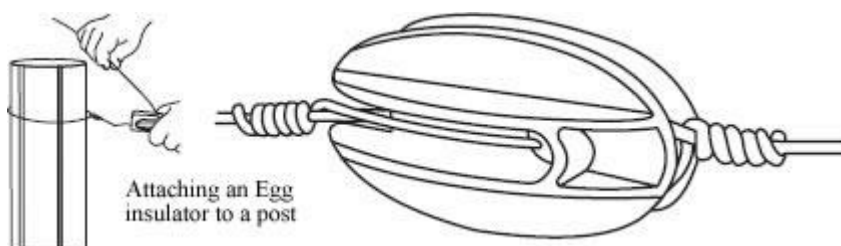

Netting

Fabricated netting is made up of zinc aluminium. HT line wires and vertical stay wires that are knotted to the line wires. The size and diameter of the wire is usually 2.5mm. Fabricated nettings have different numbers of wires, different heights and spacing to contain different animals. The recommended types are outlined on the Cyclone brochure that follows. Fabricated nettings have regular tension curves built into the line wires to provide elasticity and bounce to the netting.

Netting Properties

Stock Containment

Fabricated Netting is excellent at stock containment. It is quick to put up, is cost effective against post and rail or post and batten fences. It does not stretch and retains tension. Stock sometimes get stuck in the netting when they push through – this puts a lot of wear on the netting.

Potential for damage to stock

Very little unless protruding snags have been left when it has been erected. Stock can get stuck in netting when they push through.

Durability

The zinc aluminium coating means that it will resist corrosion for many years.

Stock suitability

Netting will suit all stock

- Sheep
- Goats
- Deer
- Cattle } Has no benefit over a wire fence
- Horses
- Emu
- Ostrich
- Alpaca

One of the main differences apart from the wire spacing is the method that the crossing wires are joined. Here are two different ways:

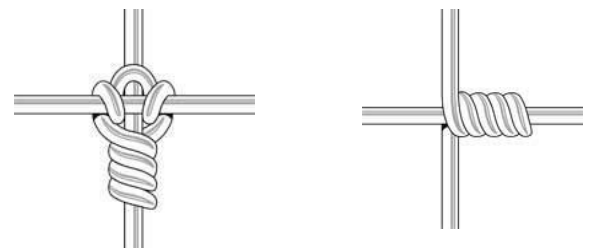



Chain link netting can be used anywhere however it is good for fixing gates. It needs to be attached with tying wire.



Tightlock Fencing

Cyclone made the world's first deer fence in 1967.

The fence consists of line, stay, and knot wires. Line wires are spaced for different stock types to provide maximum strength and security at the most needed. They are continuous in length and made from high stay wires (vertical) are continuous in length. They knots and tension curves to create overall rigidity and of any impact will spread and dissipate over the full

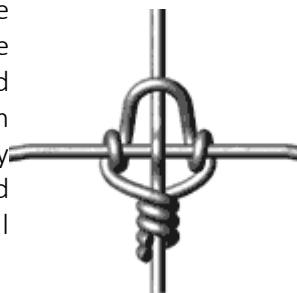

points of contact. tensile wire. The combine with the elasticity. The load fence height and

Economical galvanized products are available and offer an alternative that can be confidently used where corrosive elements are low. A select range is available in this coating.

PROPERTIES	BENEFITS
Independent knots	Increase structural strength of the fence Allow wire to follow contours
Fabricated	Faster to erect Less posts required Lower total fence cost than wire and batten
Tension curves	Easy to strain Allows for impact to dissipate over the fence and return to original condition

TYPE	APPLICATION
FAWN	Used in deer fawning paddocks due to the tighter 240 mm stay wire combined with the 89 mm line wire prevents newborn fawns from slipping through the fence.
DEER	1900 mm is the standard height. 1550 mm is used with a top wire to make up the 1900 mm height. A 150 mm stay wire is often used for additional security on boundary fence and raceways compared to a 300 mm stay for internal fence and sometimes used for boundary as an economical alternative. Used for deer and ostriches.
TOP UP	Designed to make the extra height on top of a standard fence rather than replacing the entire fence. Used for deer and ostriches.
FIELD	Regional differences dictate the different line wires and total heights. Combinations with barbed wires or electric wires complete the barrier for stock. Used in high stock pressure applications for cattle, sheep, goats and pigs.

Line Wire Spacing

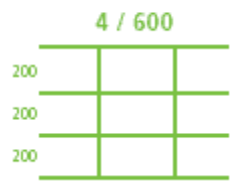
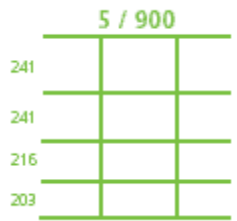
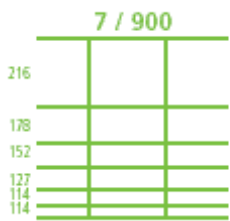
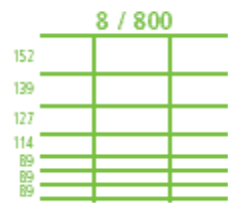
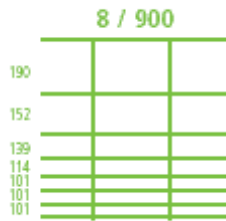
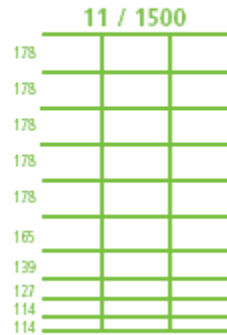
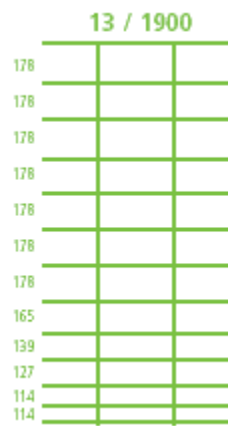
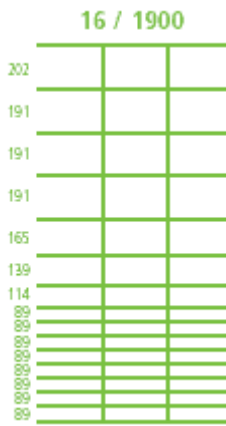

TYPE	DESCRIPTION	LINE WIRES	HEIGHT (MM)	STAY WIDTH (MM)	LENGTH (M)
DEER	A11 / 1550	11	1550	150 / 300	100
	A13 / 1900	13	1900	150 / 300	100
	A16 / 1900	16	1900	240	100
FIELD	A7 / 900	7	900	150 / 300	50 / 100
	A8 / 750	8	750	150 / 300	50 / 100
	A8 / 800	8	800	150 / 300	50 / 100
	A8 / 900	8	900	150 / 300	50 / 100
TOP UP	A4 / 600	4	600	300	200
	A5 / 600	8	600	300	200
	A5 / 900	8	900	300	200

Twinlock Fencing

Designed for stock security. Line wires are spaced for different stock types to provide strength and security at the most needed points of contact.

They are continuous in length and made from High Tensile wire unless otherwise specified. Stay wires run between the horizontal wires and are individually wrapped onto the line wire and tied in with a new stay wire that leads down to the next horizontal. Tension curves are used to create overall rigidity and elasticity. The load of the fence will spread through the hinge and along the line wires.

Economical galvanised products are available and offer an alternative that can be confidently used where corrosive elements are low. A select range is available in this coating.

TYPE	USE
Field Fence	Sheep and cattle, conservation and forestry blocks
Soft	Can be electrified for break feeding lambs / docking
Light	Low stock pressure, urban

Line Wire Spacing

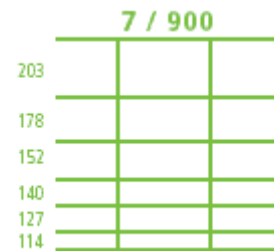
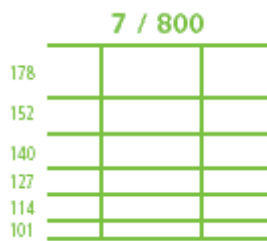
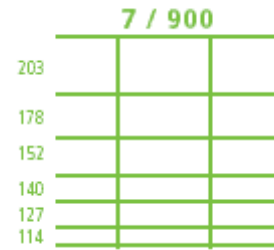
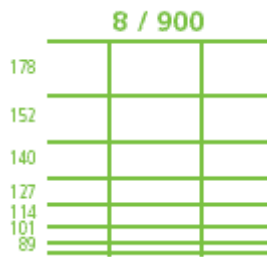

TYPE	DESCRIPTION	LINE WIRES	HEIGHT (MM)	STAY (MM)	WIDTH	ROLL LENGTH (M)
FIELD FENCE	B5 / 525	5	525	150		100
	B6 / 700	6	700	300		100
	B7 / 900	7	900	300		50 / 100
	BL7 / 800	7	800	150 / 300		50 / 100 / 200
	BL7 / 900	7	900	300		50 / 100
	B8 / 900	8	900	150 / 300		50 / 100

Section 6

Health & Safety

Employers Duties

An employer or PCBU must -

- be able to show they are managing their work risks
- identify and manage risk to people in their workplace
- include workers and family in the planning to make the farm safe
- train and supervise people who work on the farm
- make sure workers and family know about how to manage risks
- keep a record of injuries
- have procedures for dealing with workplace emergencies
- have healthy and safe facilities for workers
- make sure machinery and systems are safe for workers to use
- provide and make sure Personal Protective Equipment is used where appropriate.

Hazards

A significant hazard is defined as a hazard that is an actual or potential cause or source of:

- Serious harm (defined in the First Schedule of the Act).
- Harm the severity of whose effects on any person depend on the extent or the frequency of the person's exposure to the hazard.
- Harm that does not usually occur or is usually not easily detectable, until a significant time after exposure to the hazard.

The second component of this definition encompasses harm, which may occur progressively because of prolonged exposure to a hazardous environment, or harm which occurs because of exposure to a high concentration of a hazardous material. The consequences of exposure to a hazardous substance such as an organic solvent, or the development of strain type injuries flowing from manual handling or Occupational Overuse Syndrome is examples of harm which fall within this definition.

Where hazards are identified as significant, the Act required that ***employers take all practicable steps to eliminate the hazard, or to isolate*** the hazard from the employee if elimination is impracticable. Where neither option is practicable, employers are required to ***minimise*** the likelihood that the

hazard will be a cause or source of harm to employees.

Many of the machines are potential hazards when used incorrectly or without the right gear.

- **Augers** in the post hole bores
- **Heavy weights** on post thumpers
- **Sharp chains** on chain saws
- **PTOs** on tractors
- **Vehicles** – tractors, 4x4s and ATVs
- **Staple and nail guns**

These machines that have the potential to crush, cut, maim, break bones and kill.

Proper training is the first step to ensuring safety. Working within your own capabilities is also important. Protective gear and measures should always be used even for the smallest of jobs. Make sure that machines are kept in good order. If anything is broken, do not use it.

Always protect yourself against the sun and remember to keep hydrated.

Training and Supervision

The employers take all practicable steps to ensure that “every employee has knowledge and experience of the work they are required to carry out, or are supervised by a person who has that knowledge and experience”.

In all cases, employees must be adequately trained in the safe use of all plant and in the protective clothing and equipment, the employees may be required to use.

Recording, Investigating and Notifying Accidents

Employers are required to record and to investigate not only injury events, but also near misses and incidents.

Other Duties and Responsibilities under the Act

The Health and Safety in Employment Act also sets down a number of duties and responsibilities for employers in relation to people who are not employees, and for persons who control places of work, self-employed, principals and employees. Some examples relating to employers are:

- To take all practicable steps to ensure that no action inaction of any employee while at work harms any other person.
- When engaging contractors or subcontractors, to take all practicable steps to ensure that they are not harmed while doing work they were engaged to do.

PPE

Eye protection

To be used when working with **wire** and **stapling**. Both these materials can take out an eye.

Leg protection

Chaps and steel cap boots are important when using a chainsaw

Ear protection

When using machinery (Chainsaws, post thumpers)

Employee Responsibilities

A person at a workplace must—

- (a) take reasonable care for his or her own health and safety; and
- (b) take reasonable care that his or her acts or omissions do not adversely affect the health and safety of other persons; and
- (c) comply, as far as he or she is reasonably able, with any reasonable instruction that is given by the PCBU to allow the PCBU to comply with this Act or regulations.



DISCLAIMER

Taratahi Agricultural Training Centre (Wairarapa) Board of Trustees and any employees of Taratahi do not accept responsibility for the accuracy of this material, as our sources are many and varied. Information contained in this document is based upon the best information available to us at the time it was written and all due care was exercised in its preparation.

As it is not possible to foresee all uses of this information, or to predict all future developments and trends, any subsequent action in reliance of the accuracy of information contained, is the sole commercial decision of the user of the information and is taken at his or her own risk.

Accordingly, Taratahi disclaims any responsibility and accepts no liability whatsoever in respect of any losses or damages arising out of the use of this document, or in respect of any actions taken.